

Part Number:

KXA00420 KXA00448
 KXA00433 KXA00450
 KXA00434
 1990537

Models:

Himalayan (452cc only)
 Interceptor Bear 650
 Scram 440



WARNING: Royal Enfield genuine accessories are designed to fit only the specific Royal Enfield motorcycle(s) that are specified above. They should not be fitted to any other type of motorcycle. Pay particular attention to the warnings and cautions contained in this instruction, failure to do so may result in an incorrect installation of the accessory which could result in an unsafe riding condition and possible accident. If in any doubt always seek help from your authorised Royal Enfield dealer.



WARNING: Before starting any accessory kit installation ensure the motorcycle is supported in a stable condition. Failure to support the motorcycle correctly could lead to motorcycle damage or personal injury.



WARNING: All fixings must be tightened to the torque values specified in this instruction. Failure to tighten fixings to the correct torque could result in an unsafe riding condition and possible accident



CAUTION: Care should be taken when fitting any accessory kit. Incorrect handling of kit components or the use of incorrect tools could lead to component or motorcycle damage.

NOTE: The content of this instruction is subject to change at any time without notice or liability. Royal Enfield reserves the right to revise the information presented at any time.

Parts supplied:

KXA00433, KXA00420
 KXA00448, KXA00450

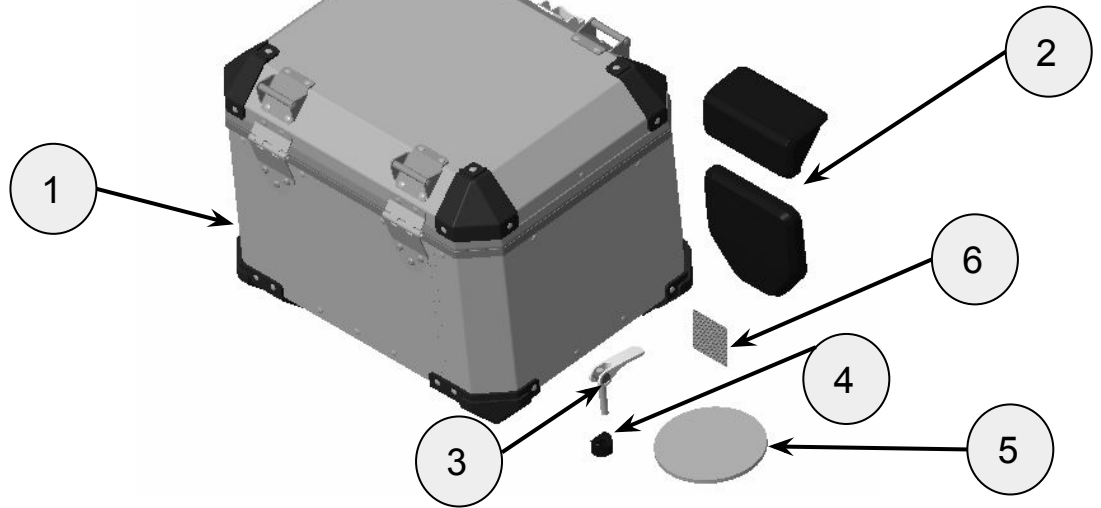

| Item | Description | Qty |
|------|-------------------|-----|
| 1 | Top box | 1 |
| 2 | Backrest pad pair | 1 |
| 3 | Locking lever | 1 |
| 4 | Locking lever cup | 1 |
| 5 | Inner cover | 1 |
| 6 | Degreaser wipe | 1 |

Parts supplied: KXA00434

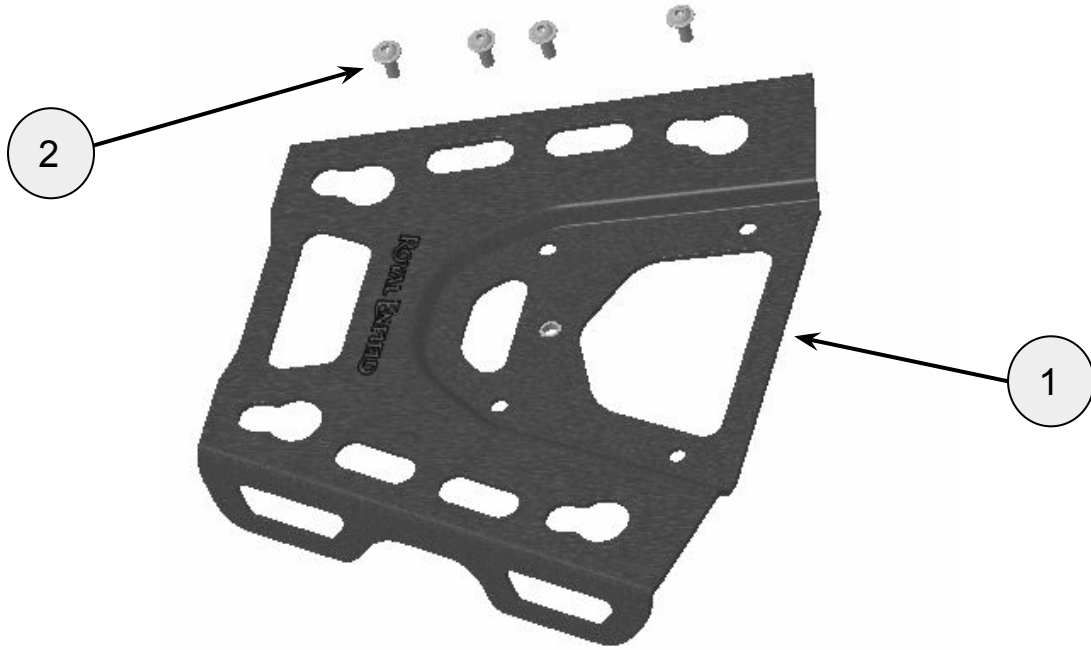

| Item | Description | Qty |
|------|---------------------|-----|
| 1 | Top box mount plate | 1 |
| 2 | Fixing, M6 x 14mm | 4 |

Parts supplied: 1990537

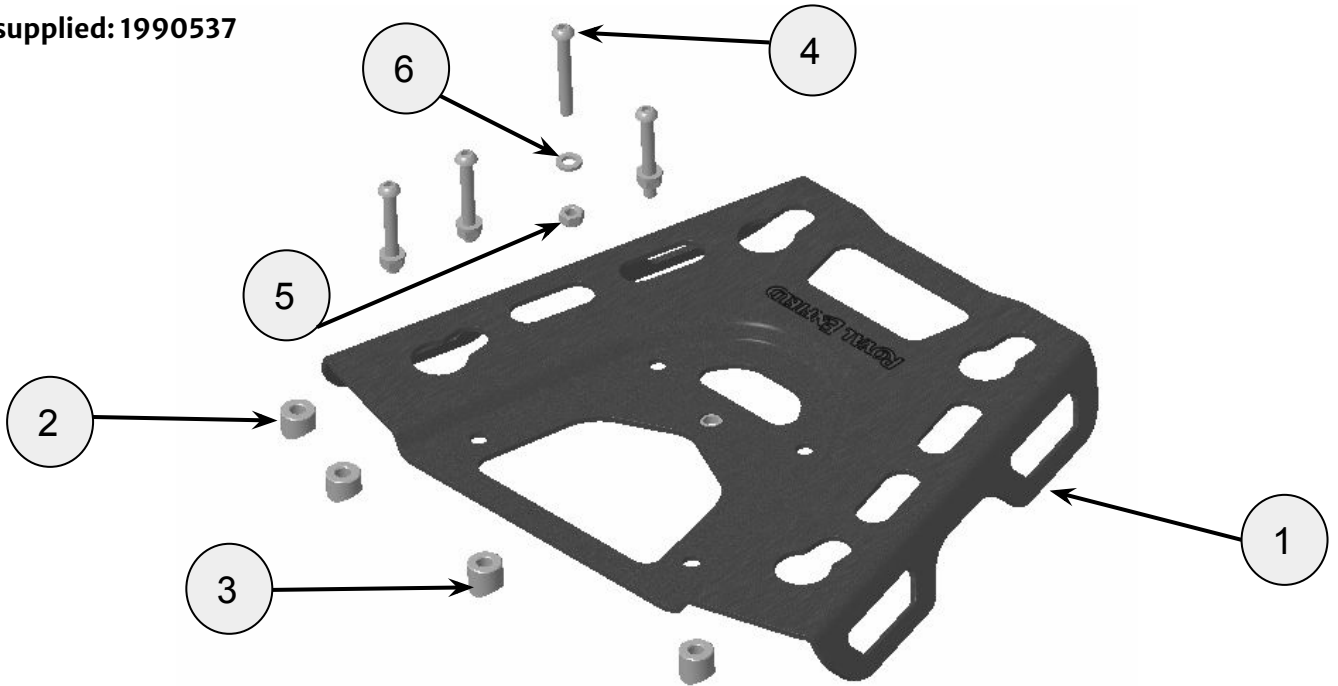

| Item | Description | Qty |
|------|---------------------|-----|
| 1 | Top box mount plate | 1 |
| 2 | Spacer, long | 2 |
| 3 | Spacer, short | 2 |
| 4 | Fixing, M6 x 40mm | 4 |
| 5 | Nut, M6 | 4 |
| 6 | Washer, M6 | 4 |

For Himalayan Models

1 Remove the four fixings (1) from the rear rack (2) and remove the standard top plate (3). Retain the plate and fixings for reuse if the motorcycle is to be returned to its original condition.



5mm hexagonal bit and ratchet

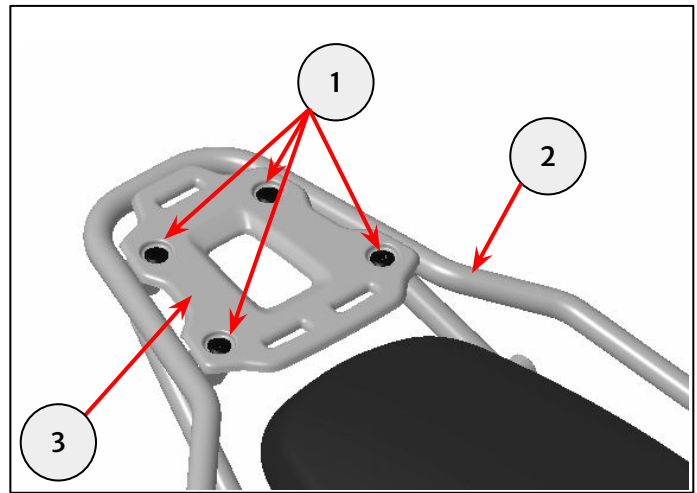

2 Place the new top plate (1) onto the rear rack. Fit the four fixings from the kit (2). Tighten to **torque specified below**.



4mm hexagonal bit and torque wrench (8Nm)
–or–
8mm socket and torque wrench (13Nm)

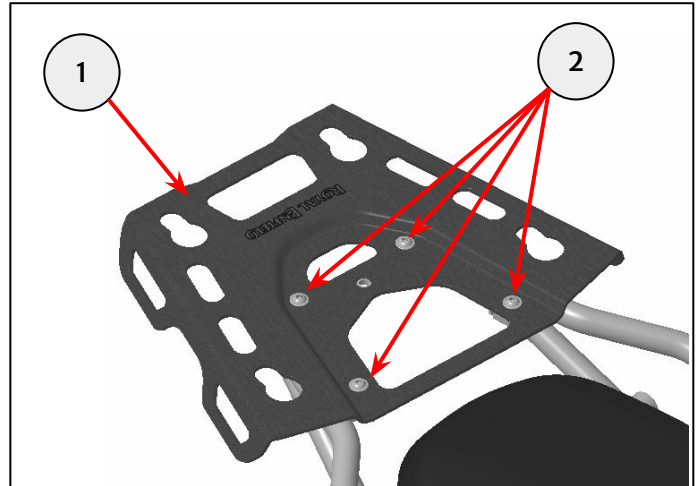

For Interceptor Bear 650 Models

Note: 1990536 Rear Rack (1) is required to be fitted first.

3 Place the two longer spacers (2) onto the rear rack front tube. Place the two shorter spacers (3) on the rear rack rear tube.

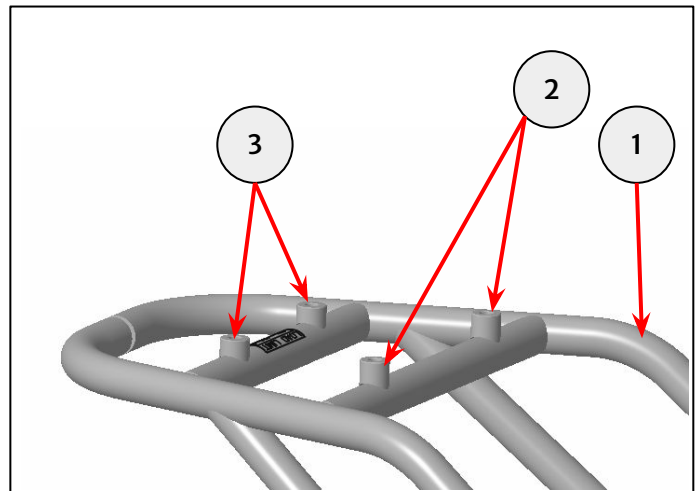

4 Place the top plate (1) onto the spacers, aligning the four mount holes with the spacers. Fit four M6 x 45mm fixings from the kit (2) through the top plate, spacers and rear rack. Fit the washers (3) and nuts (4) to all M6 x 45mm fixings. Tighten to 13Nm.



8mm socket, torque wrench and
10mm spanner

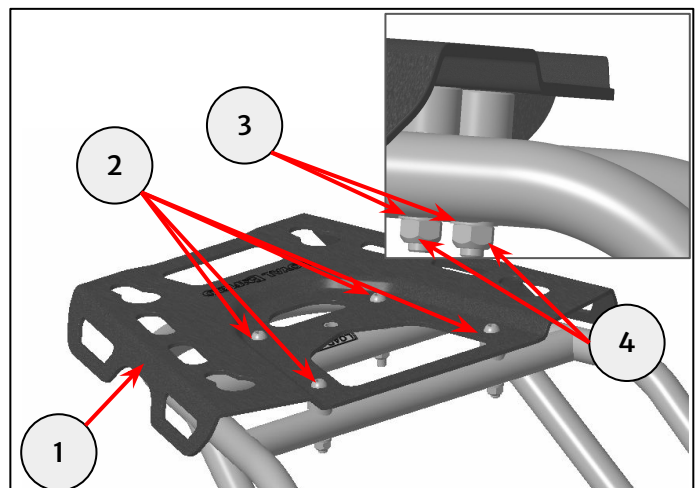

For Scram 440 Models

1 Place the top box mount plate (1) onto the rear rack mount bosses (2). Fit the four fixings from the kit (3).

Tighten to 13Nm.



8mm socket and torque wrench

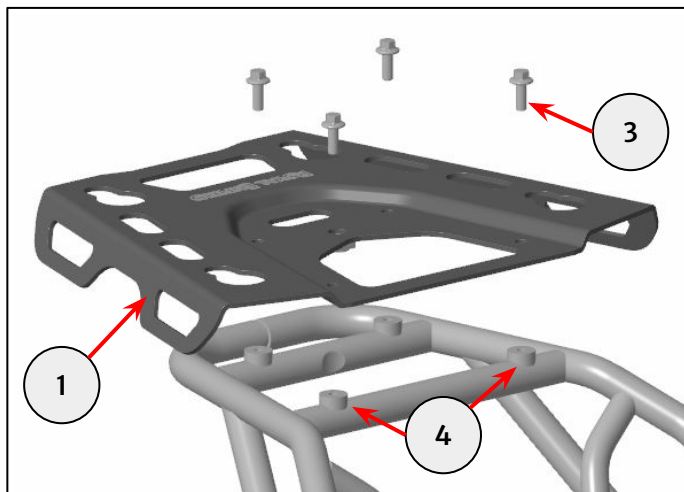

For all models

5 Position the top box (1) onto the top plate, aligning the bobbins with the four large holes (2). Push the top box towards the rear of the motorcycle, locating the bobbins into the four smaller holes (3).

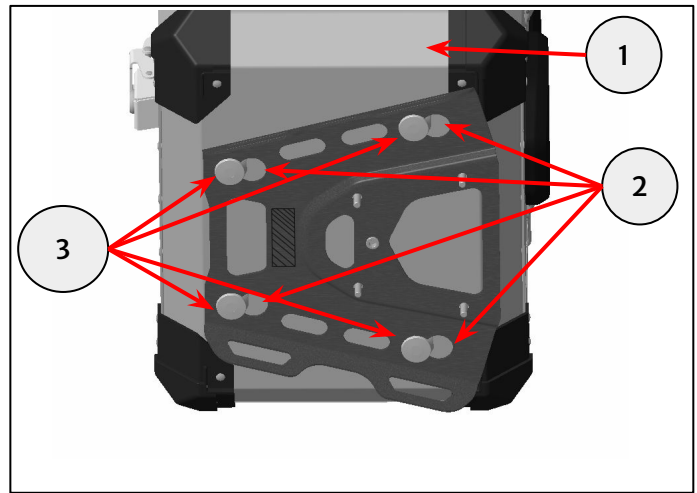

6 Place the locking lever (1) through the lever cup (2) and place the lever in the OPEN position (3).

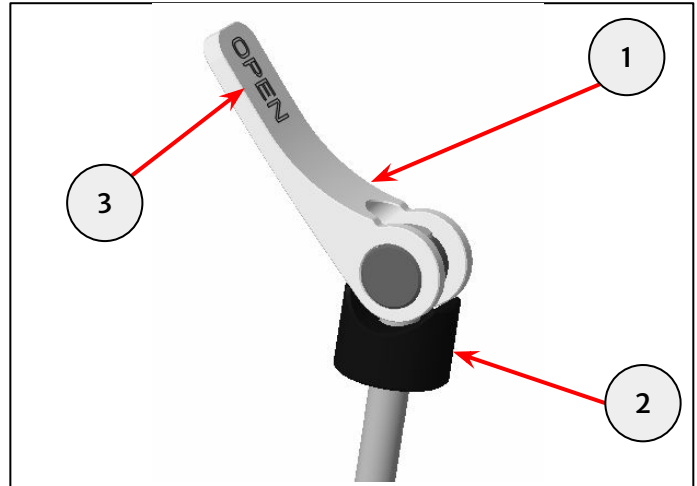

7 Open the top box lid and thread the lever (1) into the top plate from the inside of the top box. With the lever in the OPEN position (2), thread the skewer until the lever cup (3) makes contact on the base of the top box.

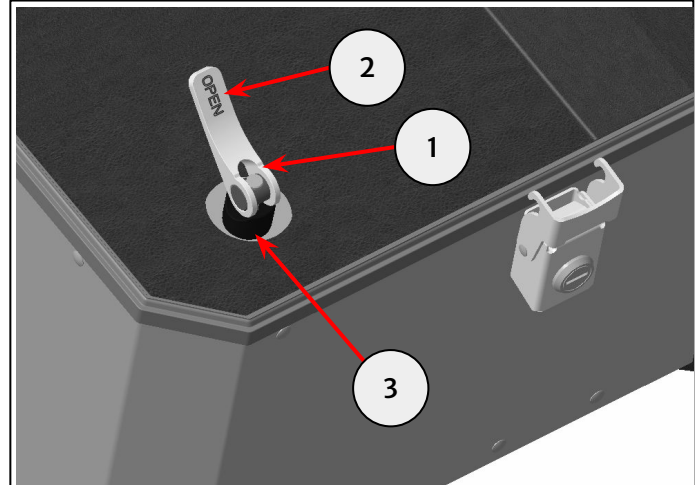

8 With the lever cup in contact on the base on the top box, thread the lever one more full rotation and then close the lever all the way. If OPEN is visible (1), the lever has not been closed.

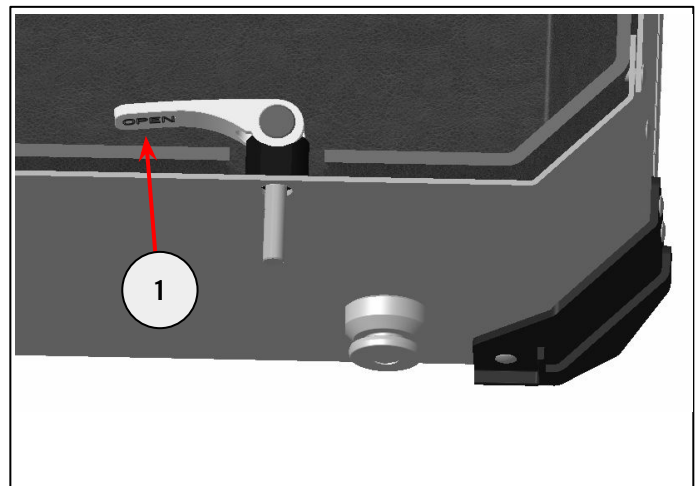

9 Cover the lever with the inner cover. Content may now be placed inside.

Warning:

Do not exceed 5kg payload. Ensure contents are adequately secured before use.

Before every use, check the lever is fully closed.

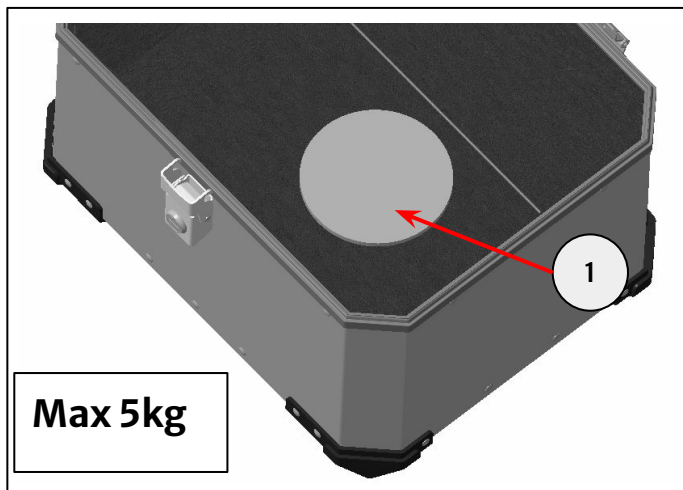

10 Using the wipe provided in the kit, clean the upper surface (1) and the top box front (2). Allow to fully dry.

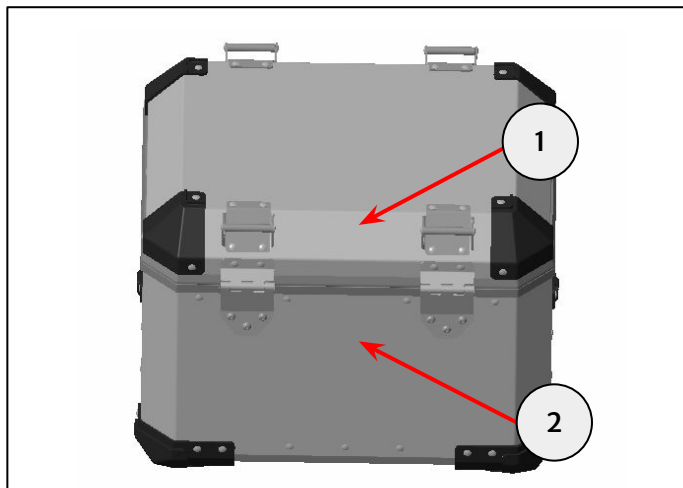

11 Peel the backing paper from the upper backrest pad (1). Ensure the pad is located centrally between the hooks (2) with the thin edge (3) on the top. Stick the pad to the top box and press firmly. Repeat for the lower backrest pad (4), ensuring the pad is centrally located between the hinges (5) and below any rivets (6).

When fitting self-adhesive parts care must be taken to make sure positioning is correct and accurate. Once the adhesive has been attached to the mounting surface, there is no satisfactory method of removal or re-positioning if incorrectly aligned. Initial bonding is instant, full bonding is achieved after 72 hours at room temperature.

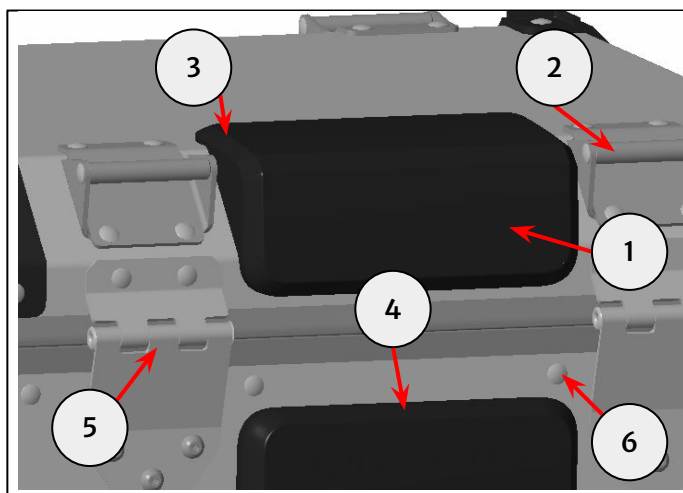

Warning:

If using the mount plate without the top box, do not exceed 5kg payload. Ensure contents are adequately secured before use.

