



Part Number:
KXA00404

Models:
Himalayan 450 (452cc only)
Guerrilla 450

 **WARNING:** Royal Enfield genuine accessories are designed to fit only the specific Royal Enfield motorcycle(s) that are specified above. They should not be fitted to any other type of motorcycle. Pay particular attention to the warnings and cautions contained in this instruction, failure to do so may result in an incorrect installation of the accessory which could result in an unsafe riding condition and possible accident. If in any doubt always seek help from your authorised Royal Enfield dealer.

 **WARNING:** Before starting any accessory kit installation ensure the motorcycle is supported in a stable condition. Failure to support the motorcycle correctly could lead to motorcycle damage or personal injury.

 **WARNING:** All fixings must be tightened to the torque values specified in this instruction. Failure to tighten fixings to the correct torque could result in an unsafe riding condition and possible accident

 **CAUTION:** Care should be taken when fitting any accessory kit. Incorrect handling of kit components or the use of incorrect tools could lead to component or motorcycle damage.

NOTE: The content of this instruction is subject to change at any time without notice or liability. Royal Enfield reserves the right to revise the information presented at any time.

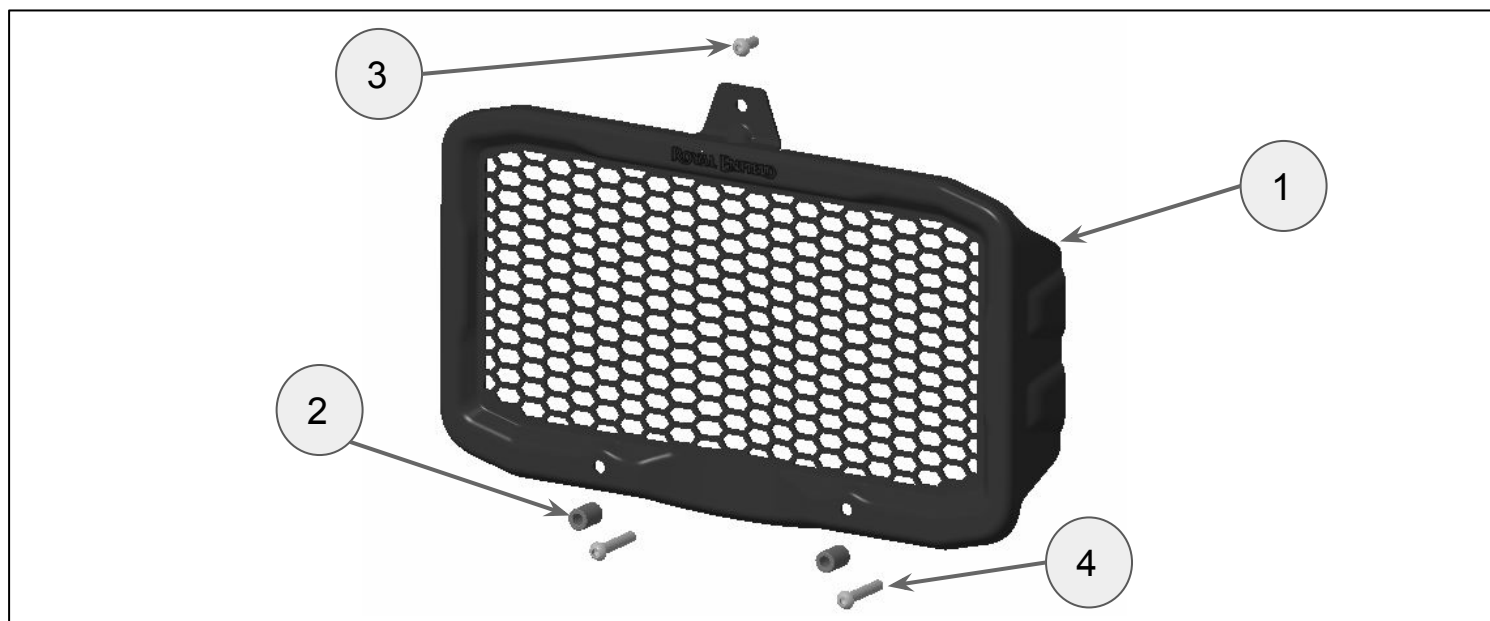

Item	Description	Qty
1	Radiator Guard	1
2	Spacer	2
3	Fixing, M6 x 14mm	1
4	Fixing, M6 x 35mm	2

1 Remove the standard radiator guard (1) from the radiator by removing the three fixings (2). Retain the guard and fixings for reuse if the motorcycle is to be returned to its original condition.

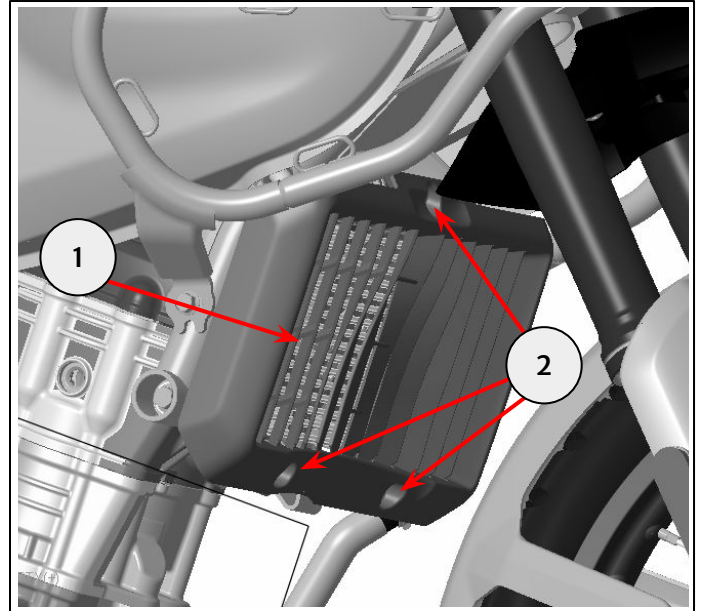

10mm socket and ratchet

2 Using the M6 x 14mm fixing from the kit (1), attach the top of the new radiator guard (2) to the top of the radiator (3). Do not fully tighten at this stage.

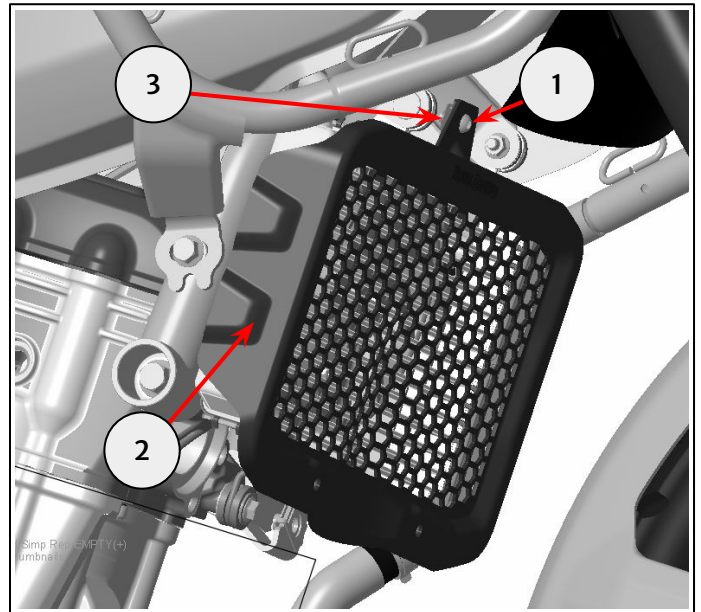

4mm hexagonal bit and ratchet

3 Place a spacer from the kit (1) between the radiator guard (2) and the motorcycle's mount point (3). Fit fixing M6 x 35mm (4) through the radiator and spacer. Do not fully tighten at this stage. Repeat for the remaining spacer and fixing.

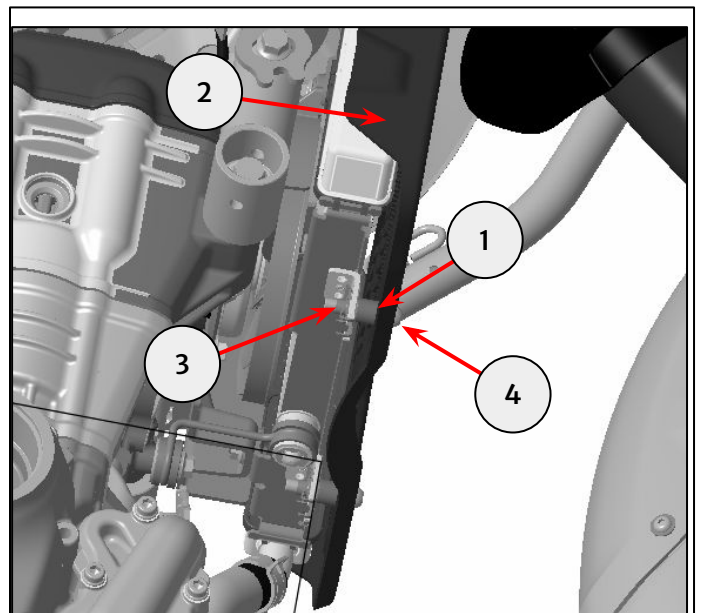

4mm hexagonal bit and ratchet

4 Tighten the lower fixings (1) to **10Nm**. Tighten the top fixing (2) to **10Nm**.



4mm hexagonal bit and torque wrench

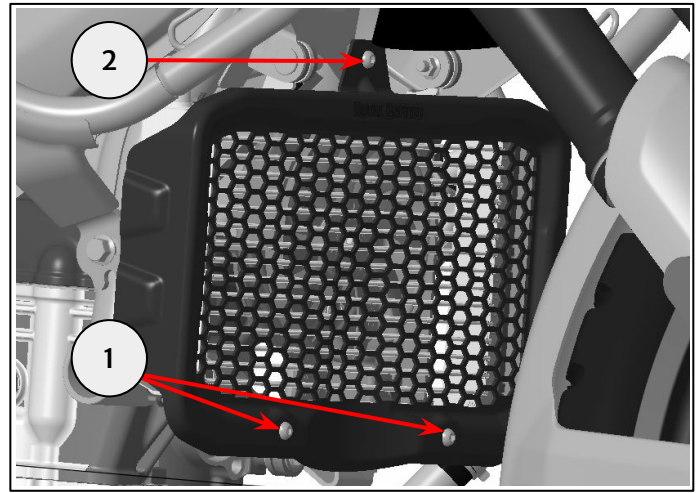

CAUTION: Regularly check the radiator guard for obstruction by insects, leaves or mud. Clean off any obstructions with a stream of low pressure water.

Interference with the radiator airflow can cause overheating, potentially resulting in engine damage.



WARNING: After fitting any genuine Royal Enfield accessory always ride the motorcycle with caution and allow time to become familiar with any change in the motorcycle handling characteristics. Failure to become familiar with any change in the motorcycle handling characteristics may cause the motorcycle to become unstable and result in an accident.