

Part Number:
KXA00200, KXA00201

Models: SUPER METEOR
SHOTGUN 650

WARNING: Royal Enfield genuine accessories are designed to fit only the specific Royal Enfield motorcycle(s) that are specified above. They should not be fitted to any other type of motorcycle. Pay particular attention to the warnings and cautions contained in this instruction, failure to do so may result in an incorrect installation of the accessory which could result in an unsafe riding condition and possible accident. If in any doubt always seek help from your authorised Royal Enfield dealer.

WARNING: Before starting any accessory kit installation ensure the motorcycle is supported in a stable condition. Failure to support the motorcycle correctly could lead to motorcycle damage or personal injury.

WARNING: All fixings must be tightened to the torque values specified in this instruction. Failure to tighten fixings to the correct torque could result in an unsafe riding condition and possible accident

CAUTION: Care should be taken when fitting any accessory kit. Incorrect handling of kit components or the use of incorrect tools could lead to component or motorcycle damage.

NOTE: The content of this instruction is subject to change at any time without notice or liability. Royal Enfield reserves the right to revise the information presented at any time.

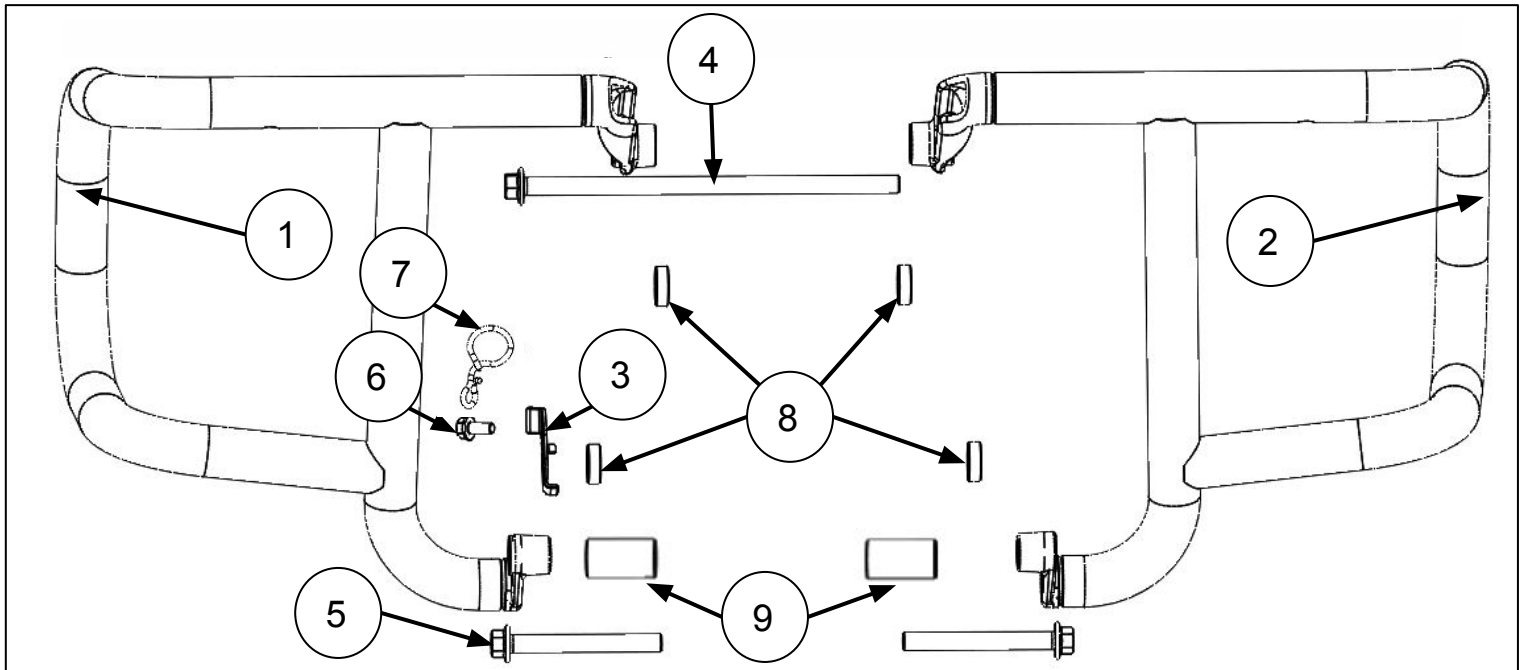

Item	Description	Qty
1	Engine guard, right hand	1
2	Engine guard, left hand	1
3	Reservoir bracket (Super Meteor only)	1
4	Fixing, M10 x 210mm	1
5	Fixing, M10 x 85mm	2
6	Fixing, M6 x 14mm (Super meteor only)	2
7	Clutch cable guide (Super meteor only)	1
8	Spacer boss 22 x 7mm	4
9	Spacer boss 20 x 36.5mm (Shotgun 650 only)	2

Fitment on the Super Meteor:

1 Remove the brake fluid reservoir (1) by removing the fixing (2).

Without removing the reservoir from the hose, pinch the clip (3) and rotate the reservoir (1) by 180°.

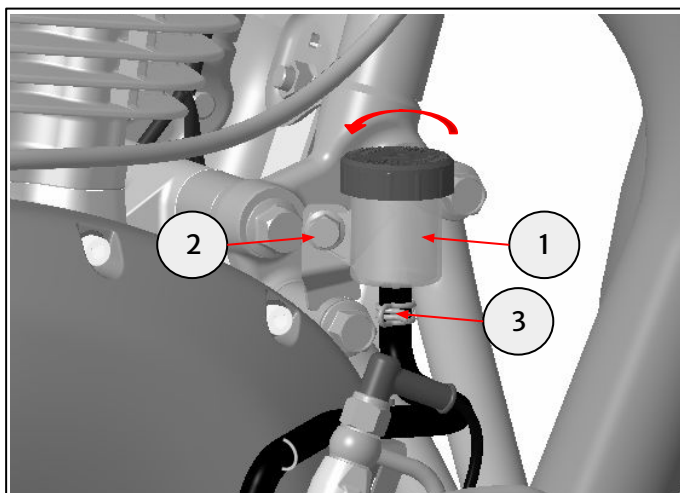

10mm socket and ratchet



Long nose pliers

2 Remove the engine mount fixing (1). Retain the nut for reuse. Retain the fixing and washer for reuse if the motorcycle is to be returned to its original condition.

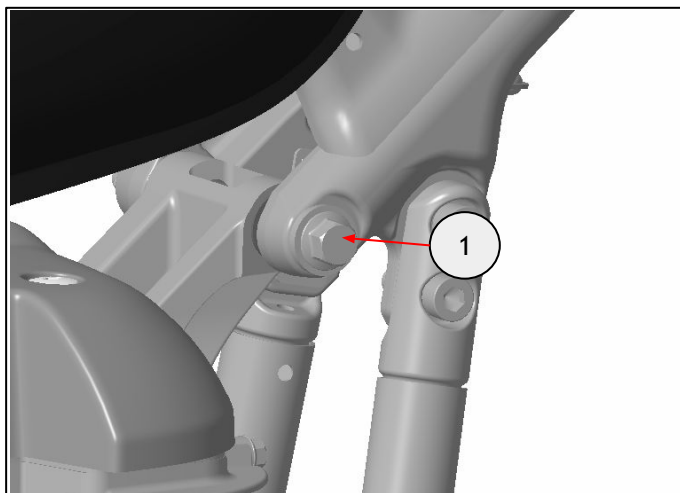

14mm socket and ratchet



14mm spanner

3 Remove the right foot peg fixing (1). Retain the fixing for reuse if the motorcycle is to be returned to its original condition.

Repeat step 3 on the left side.

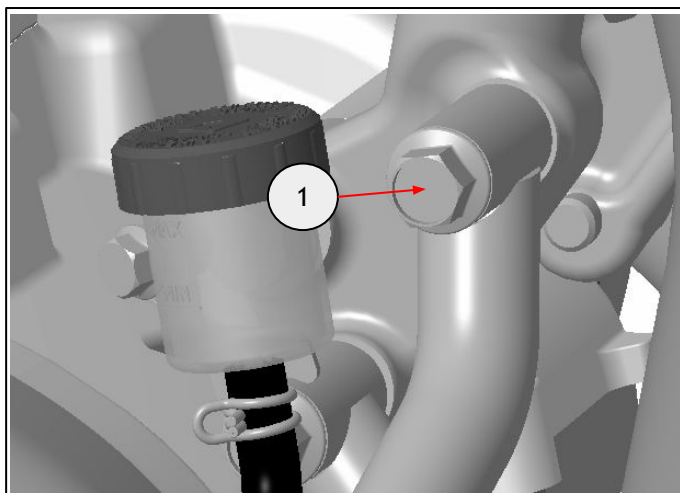

14mm socket and ratchet

4 Align the right hand engine guard (1) with the upper engine mount. Position the 22 x 7mm spacer (2) from the kit between the right hand engine guard and the frame. Fit the M10 x 212mm fixing (3) from the kit.

Repeat step 4 on the left side.

Fit the nut (4) removed in step 2.

Do not fully tighten at this stage



13mm socket and ratchet



14mm spanner

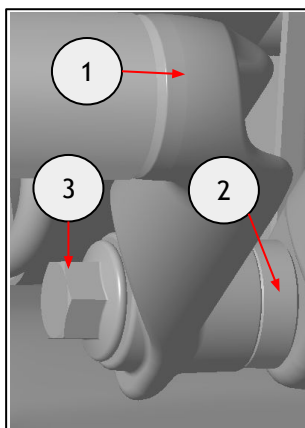

Right hand side

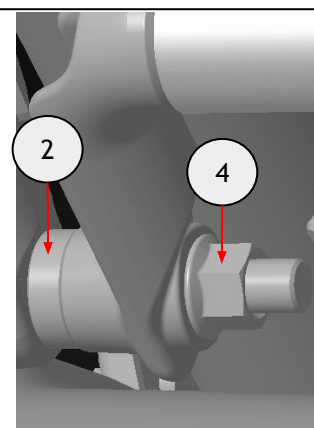

Left hand side

5 Align the 22 x 7mm spacer (1) from the kit between the frame (2) and the right hand engine guard (3). Align the reservoir bracket (4) with the right hand engine guard. Fit the M10 x 85mm fixing (5) from the kit to secure the right hand engine guard.

Repeat step 5 on the left side without the brake reservoir bracket.

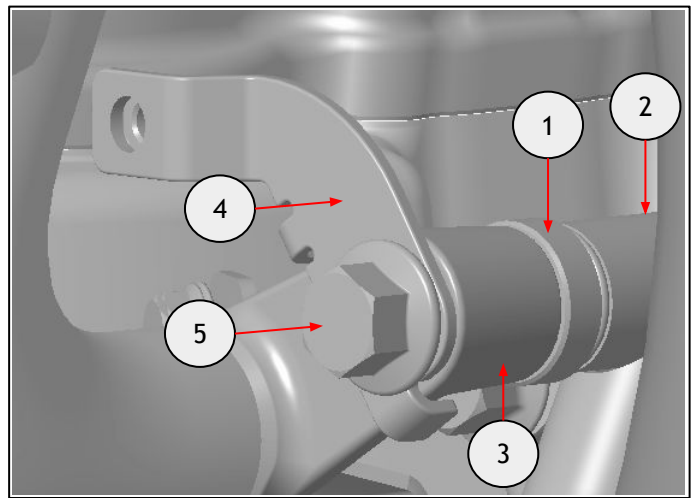

13mm socket and ratchet

6 Tighten the fixing (1) to **70Nm**.
Tighten the fixings (2) to **45Nm**.
Repeat step 6 on the left side.



13mm socket and torque wrench



14mm spanner

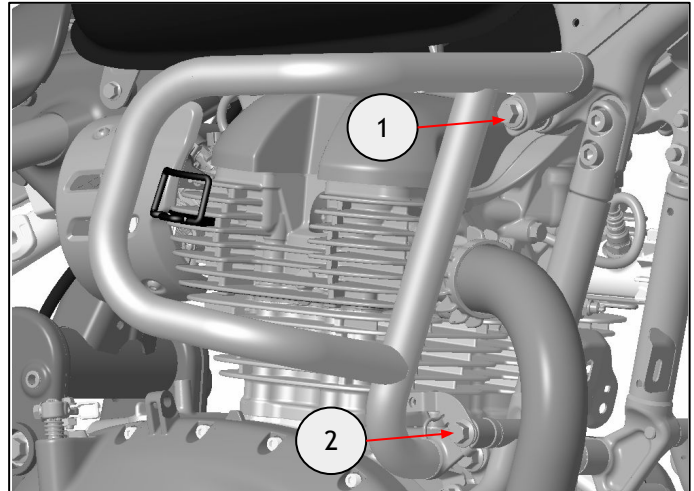

7 Fix the reservoir (1) on the reservoir bracket (2) using the M6 x 14mm fixing (3) from the kit.
Tighten the fixing (3) to **3Nm**.



10mm socket and torque wrench

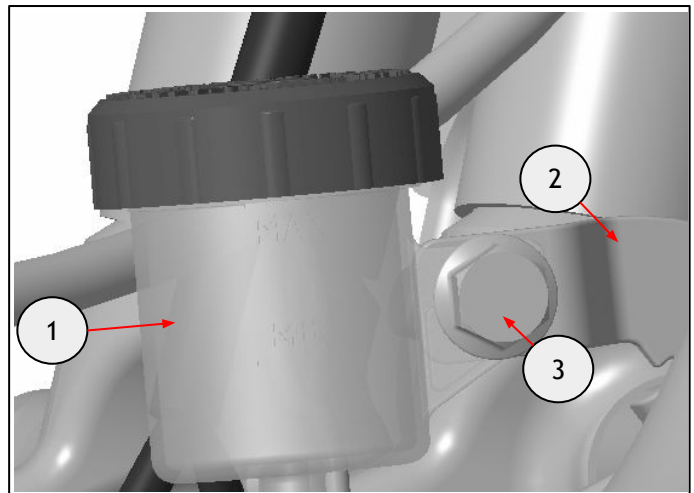

8 Fit the cable assembly (1) through the cable guide (2). Fix the cable guide on the existing reservoir bracket (3) using the M6 x 14mm fixing (4) from the kit.
Tighten the fixing (4) to **3Nm**.



10mm socket and torque wrench

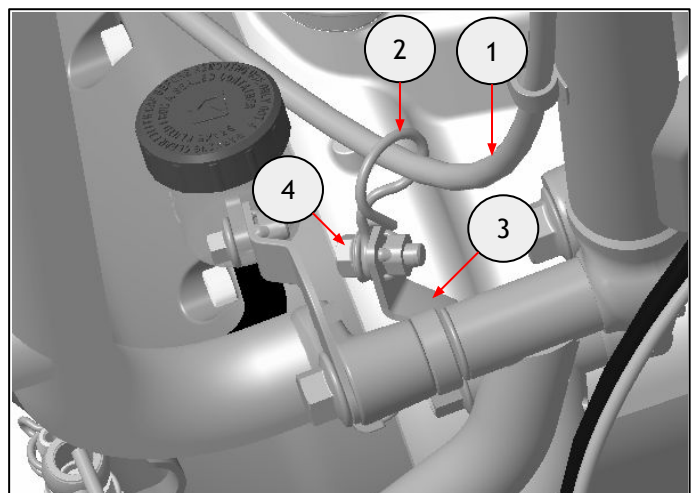



WARNING: After fitting any genuine Royal Enfield accessory always ride the motorcycle with caution and allow time to become familiar with any change in the motorcycle handling characteristics. Failure to become familiar with any change in the motorcycle handling characteristics may cause the motorcycle to become unstable and result in an accident.

Fitment on the Shotgun 650:

12 Remove the engine mount fixing (1). Retain the nut for reuse. Retain the fixing and washer for reuse if the motorcycle is to be returned to its original condition.



14mm socket and ratchet



14mm spanner

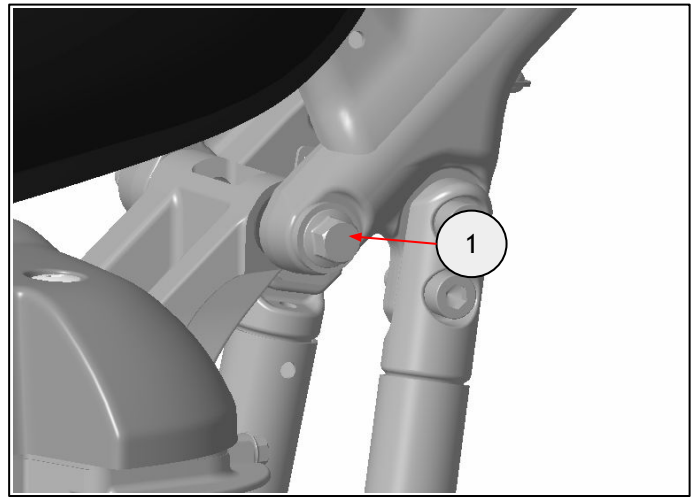

13 Remove the fixing (1). Retain for reuse if the motorcycle is to be returned to its original condition. Repeat step 13 on the left side.



14mm socket and ratchet

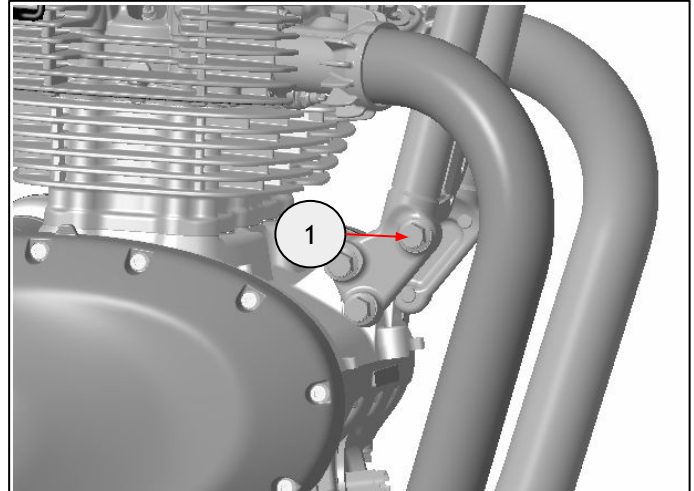

14 Align the right hand engine guard (1) with the upper engine mount. Position the 22 x 7mm spacer (2) from the kit between the right hand engine guard and fixing. Fit the M10 x 210mm fixing (3) from the kit.

Repeat step 14 on the left side.
Fit the nut (4) removed in step 12.
Do not fully tighten at this stage



13mm socket and ratchet



14mm spanner

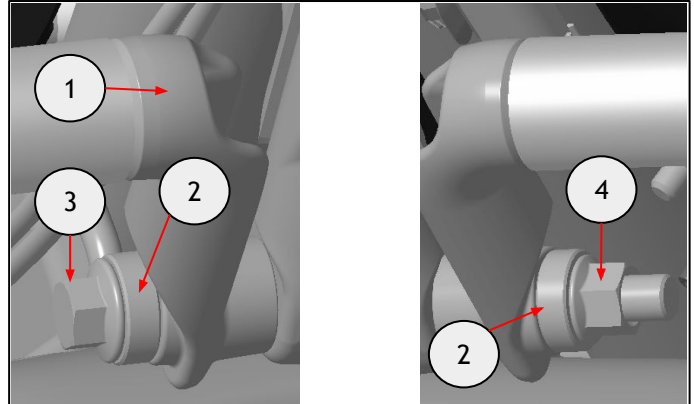

Right hand side

Left hand side

15 Align the 20 x 36.5mm spacer (1) from the kit between the frame (2) and right hand engine guard (3).

Loosely fit the M10 x 85 fixing (4) from the kit through the 22 x 7mm spacer (5) from the kit to secure the right hand engine guard.
Repeat step 15 for left hand side.



13mm socket and ratchet

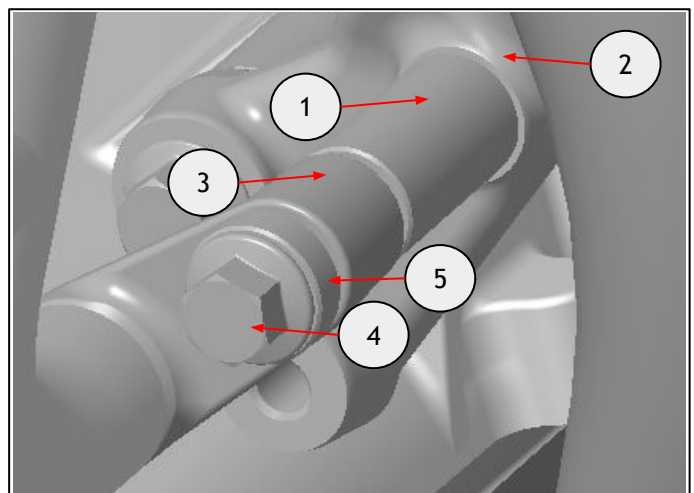

16 Tighten the fixing (1) to **70Nm**.
Tighten the fixing (2) to **45Nm**.
Repeat step 16 on the left side.



13mm socket and torque wrench



14mm spanner

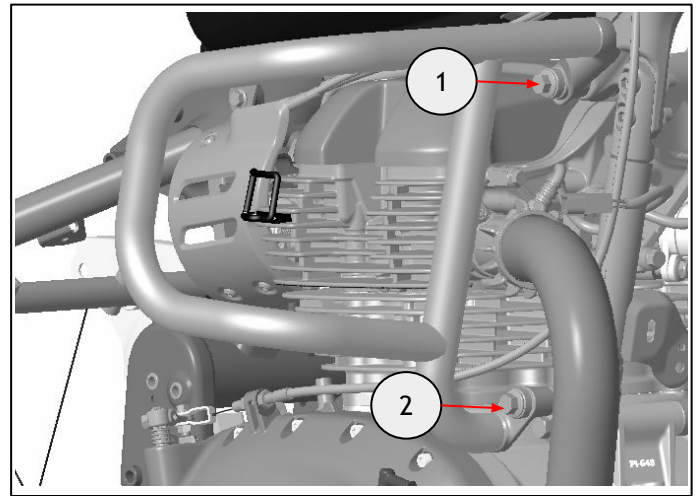

WARNING: After fitting any genuine Royal Enfield accessory always ride the motorcycle with caution and allow time to become familiar with any change in the motorcycle handling characteristics. Failure to become familiar with any change in the motorcycle handling characteristics may cause the motorcycle to become unstable and result in an accident.