

Part Number:

1990633 (Air Fly), 1990634 (Octagon), 1990635 (Trapezium)

Models:

Classic 350cc, Classic 500cc, Bullet 350cc, Bullet 500cc & Electra 350cc

WARNING: Royal Enfield genuine accessories are designed to fit only the specific Royal Enfield motorcycle(s) that are specified above. They should not be fitted to any other type of motorcycle. Pay particular attention to the warnings and cautions contained in this instruction, failure to do so may result in an incorrect installation of the accessory which could result in an unsafe riding condition and possible accident. If in any doubt always seek the help from your authorised Royal Enfield dealer.

WARNING: Before starting any accessory kit installation ensure the motorcycle is supported in a stable condition. Failure to support the motorcycle correctly could lead to motorcycle damage or personal injury.

WARNING: All fixings must be tightened to the torque values specified in this instruction. Failure to tighten fixings to the correct torque could result in an unsafe riding condition and possible accident.

CAUTION: Care should be taken when fitting any accessory kit. Incorrect handling kit components or the use of incorrect tools could lead to component or motorcycle damage.

NOTE: The content of this instruction is subject to change at any time without notice or liability. Royal Enfield reserves the right to revise the information presented at any time.

1990633 - Air Fly

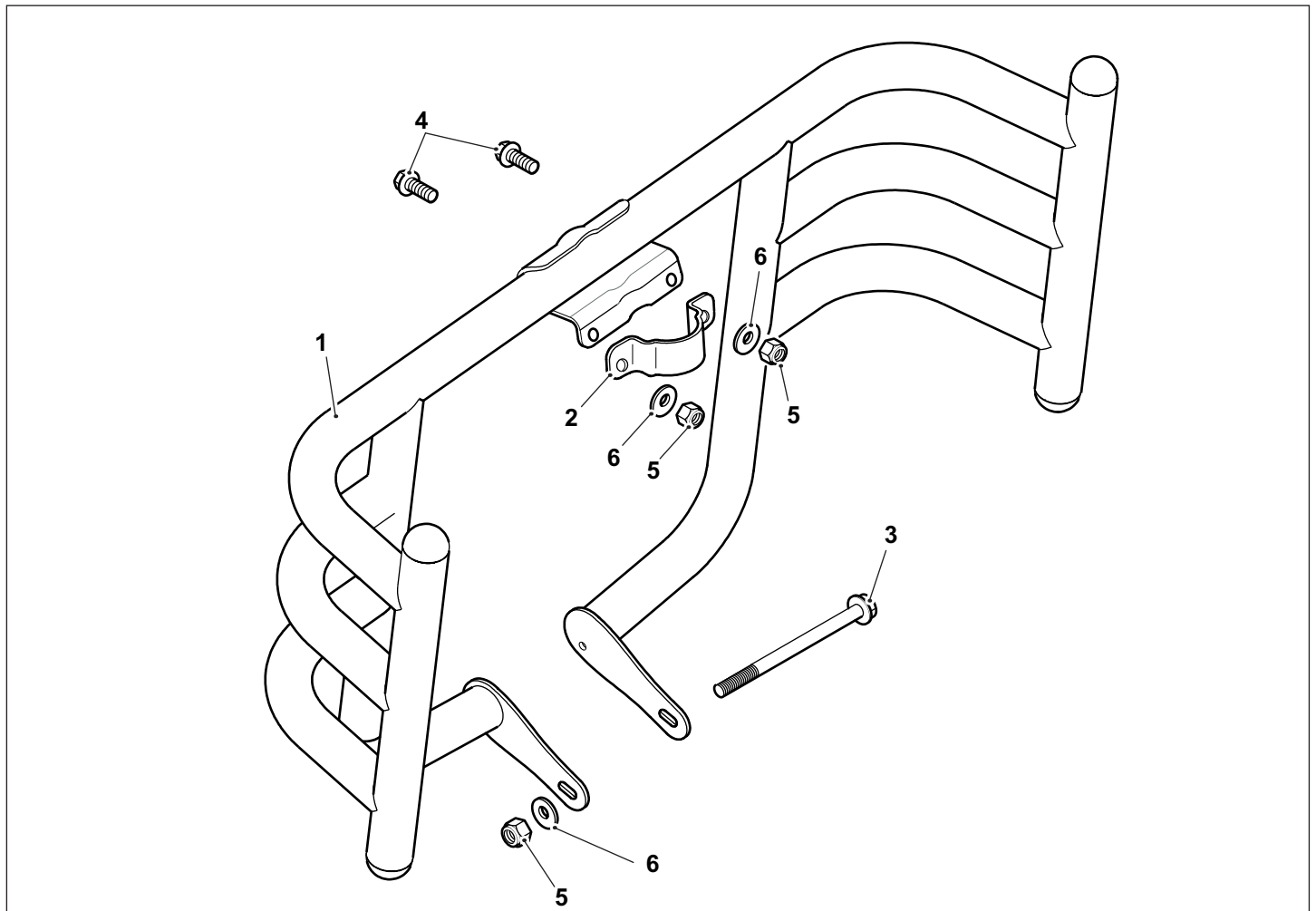

| Item | Description | Qty |
|------|--------------------|-----|
| 1 | Engine Guard | 1 |
| 2 | Rear clamp | 1 |
| 3 | Fixing, M8 x 120mm | 1 |

| Item | Description | Qty |
|------|-------------------|-----|
| 4 | Fixing, M8 x 20mm | 2 |
| 5 | Locknut, M8 | 3 |
| 6 | Washer, M8 | 3 |

1990634- Octagon

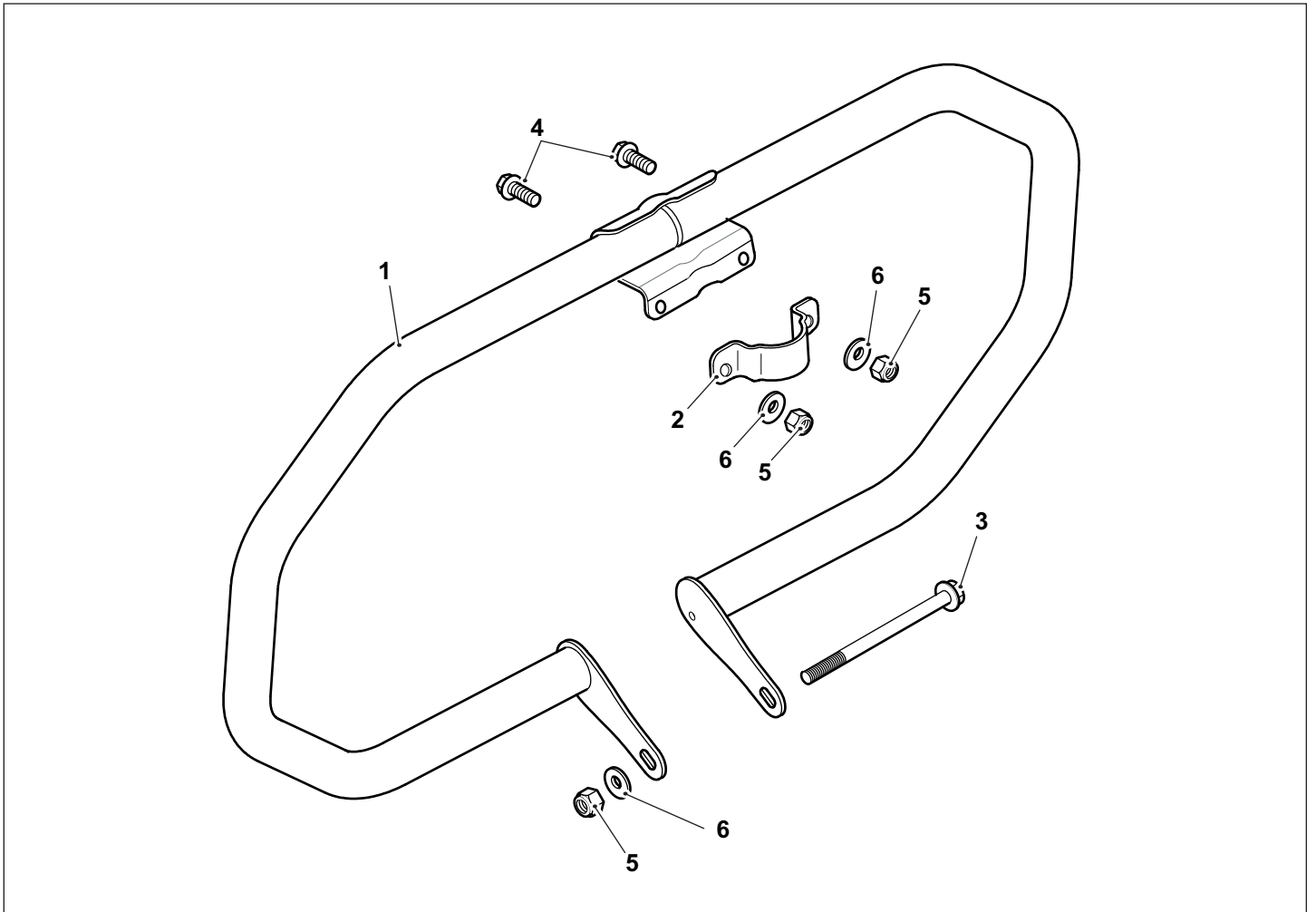

| Item | Description | Qty |
|------|--------------------|-----|
| 1 | Engine Guard | 1 |
| 2 | Rear clamp | 1 |
| 3 | Fixing, M8 x 120mm | 1 |

| Item | Description | Qty |
|------|-------------------|-----|
| 4 | Fixing, M8 x 20mm | 2 |
| 5 | Locknut, M8 | 3 |
| 6 | Washer, M8 | 3 |

1990635 - Trapezium

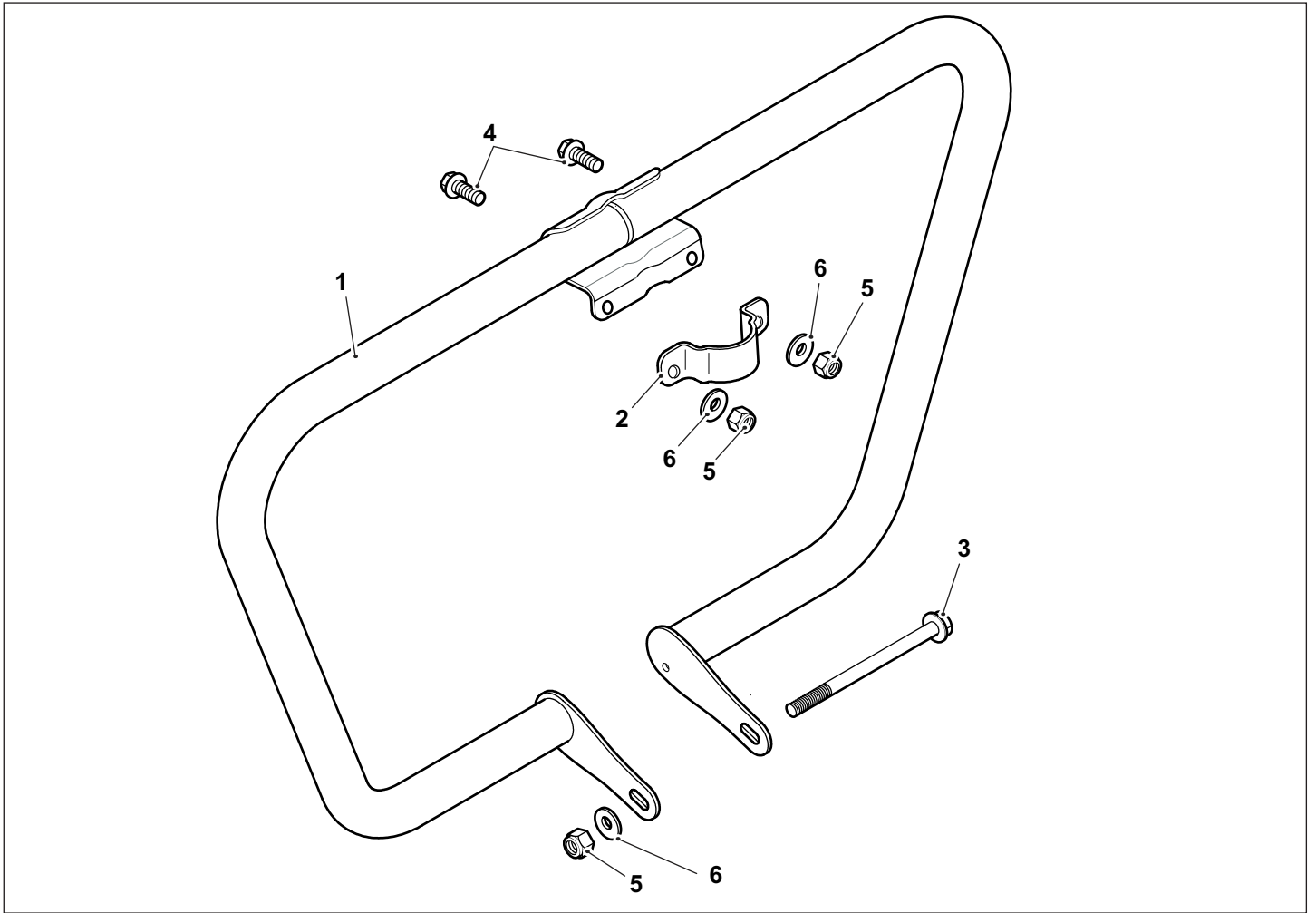

| Item | Description | Qty |
|------|--------------------|-----|
| 1 | Engine Guard | 1 |
| 2 | Rear clamp | 1 |
| 3 | Fixing, M8 x 120mm | 1 |

| Item | Description | Qty |
|------|-------------------|-----|
| 4 | Fixing, M8 x 20mm | 2 |
| 5 | Locknut, M8 | 3 |
| 6 | Washer, M8 | 3 |

NOTE: Although the shape of the Air Fly, Octagon and Trapezium engine guards are different, the method of fitment is the same for all types.

WARNING: If the engine has recently been running the exhaust system will be hot. Before working near to the exhaust system always allow time for the exhaust system to cool. Touching any part of a hot exhaust system will cause burn injuries.

1 Place the motorcycle on the centre stand.

2 Remove the top rubber strap (1) securing the wiring harnesses to the motorcycle frame, as shown. Retain the strap for reuse.

3 Position the rear clamp (1) from the kit on the rear of the frame down tube (2) just below the frame plates (3), in the orientation shown.

NOTE: The fixing holes (4) should be positioned towards the bottom of the clamp (1), as shown.

Ensure no wiring harnesses become trapped between the rear clamp and motorcycle frame.

WARNING: A wiring harness which becomes trapped or pinched during installation of the engine guard may lead to wiring harness damage and electrical malfunctions.

4 Ensure the motorcycle frame is clean. Pay particular attention to the area below the front lower engine mounting. The hole (1) through the frame (2) should be clear of any dirt or debris.

5 Align the lower mountings of the engine guard (1) with the hole (2) through the bottom of the motorcycle frame. Fit the M8 x 120mm fixing (3) provided, from the left hand side of the motorcycle, as shown.

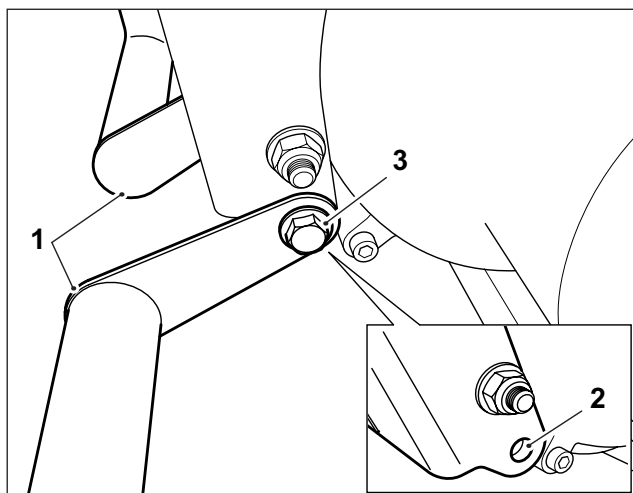
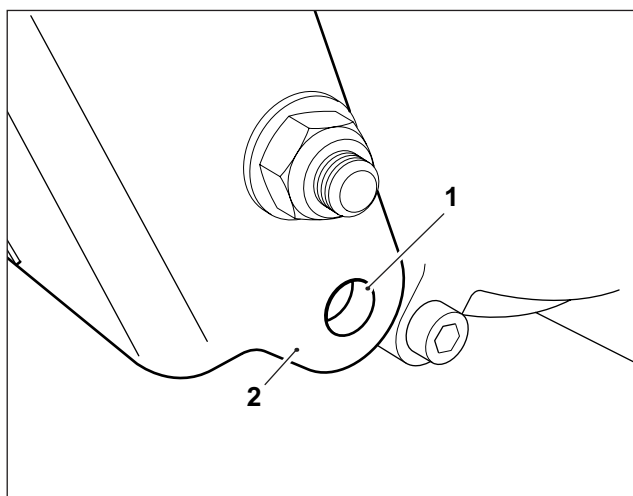
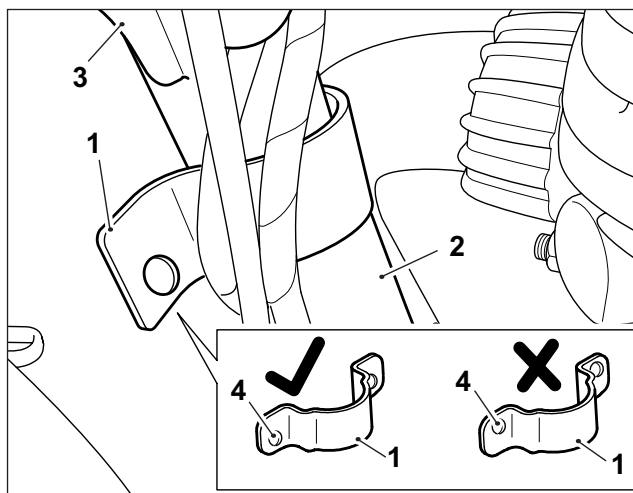
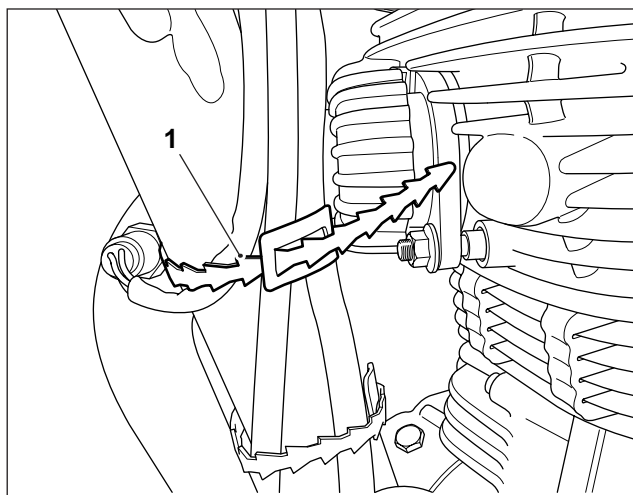

6 Fit an M8 locknut (1) and M8 washer (2) from the kit on to the lower engine guard fixing (3) at the left hand side of the motorcycle. Do not fully tighten the fixing at this stage.

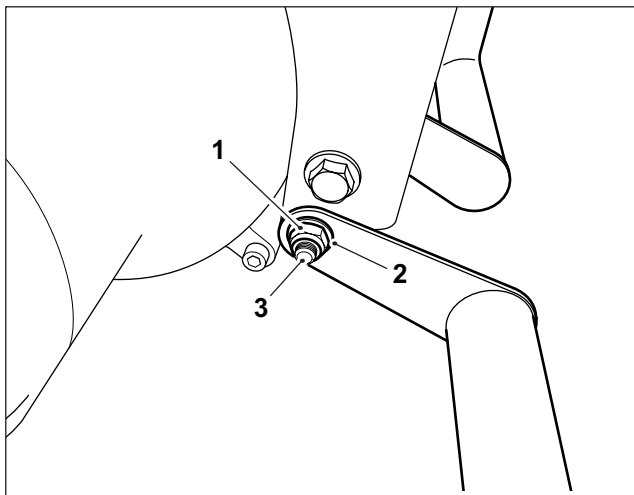

7 Position the top engine guard mounting (1) against the motorcycle frame down tube. Align the rear clamp (2) with the engine guard top mounting and fit M8 x 20mm fixings (3) M8 washers (4) and M8 locknuts (5) from the kit to the left hand and right hand side of the mounting (left hand side shown). Ensure no wiring harnesses become trapped between the rear clamp, engine guard and motorcycle frame. Tighten the fixings (3) evenly to maintain an equal gap between the engine guard mounting (1) and rear clamp (2) on both sides of the motorcycle.

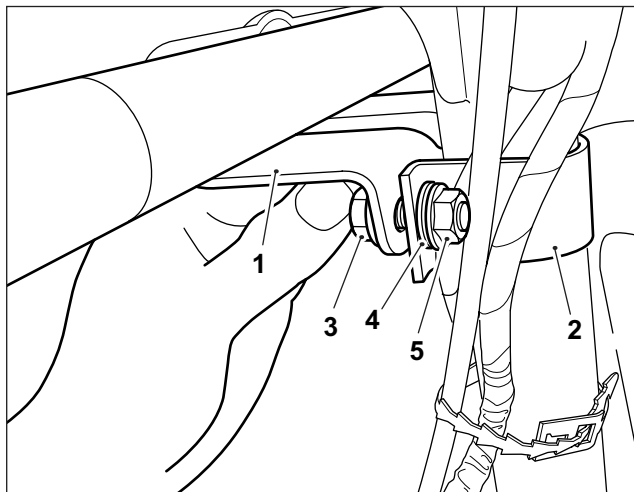

Apply a final torque to both fixings of **22Nm**.

WARNING: A wiring harness which becomes trapped or pinched during installation of the engine guard may lead to wiring harness damage and electrical malfunctions.

8 Tighten the engine guard lower fixing to **22Nm**.

9 Refit the rubber strap (1) to retain the wiring harnesses to the motorcycle frame, as shown.

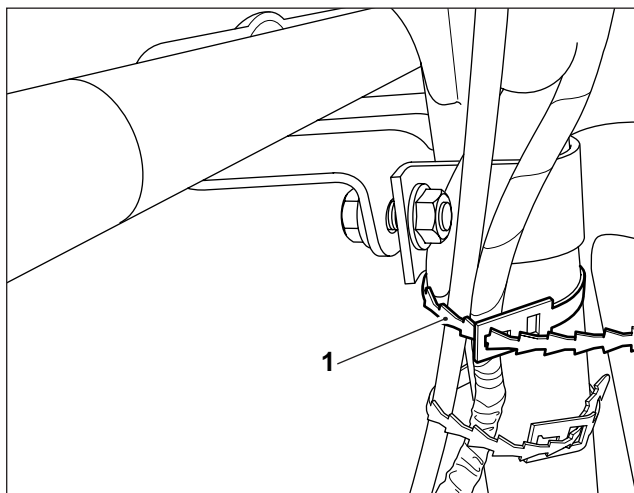

WARNING: After fitting any genuine Royal Enfield accessory always ride the motorcycle with caution and allow time to become familiar with any change in the motorcycle handling characteristics. Failure to become familiar with any change in the motorcycle handling characteristics may cause the motorcycle to become unstable and result in an accident.