





Part Number:
KXA00481

Models:
Guerrilla 450

-  **WARNING:** Royal Enfield genuine accessories are designed to fit only the specific Royal Enfield motorcycle(s) that are specified above. They should not be fitted to any other type of motorcycle. Pay particular attention to the warnings and cautions contained in this instruction, failure to do so may result in an incorrect installation of the accessory which could result in an unsafe riding condition and possible accident. If in any doubt always seek help from your authorised Royal Enfield dealer.
-  **WARNING:** Before starting any accessory kit installation ensure the motorcycle is supported in a stable condition. Failure to support the motorcycle correctly could lead to motorcycle damage or personal injury.
-  **WARNING:** All fixings must be tightened to the torque values specified in this instruction. Failure to tighten fixings to the correct torque could result in an unsafe riding condition and possible accident
-  **CAUTION:** Care should be taken when fitting any accessory kit. Incorrect handling of kit components or the use of incorrect tools could lead to component or motorcycle damage.

NOTE: The content of this instruction is subject to change at any time without notice or liability. Royal Enfield reserves the right to revise the information presented at any time.

Parts Supplied: KXA00481

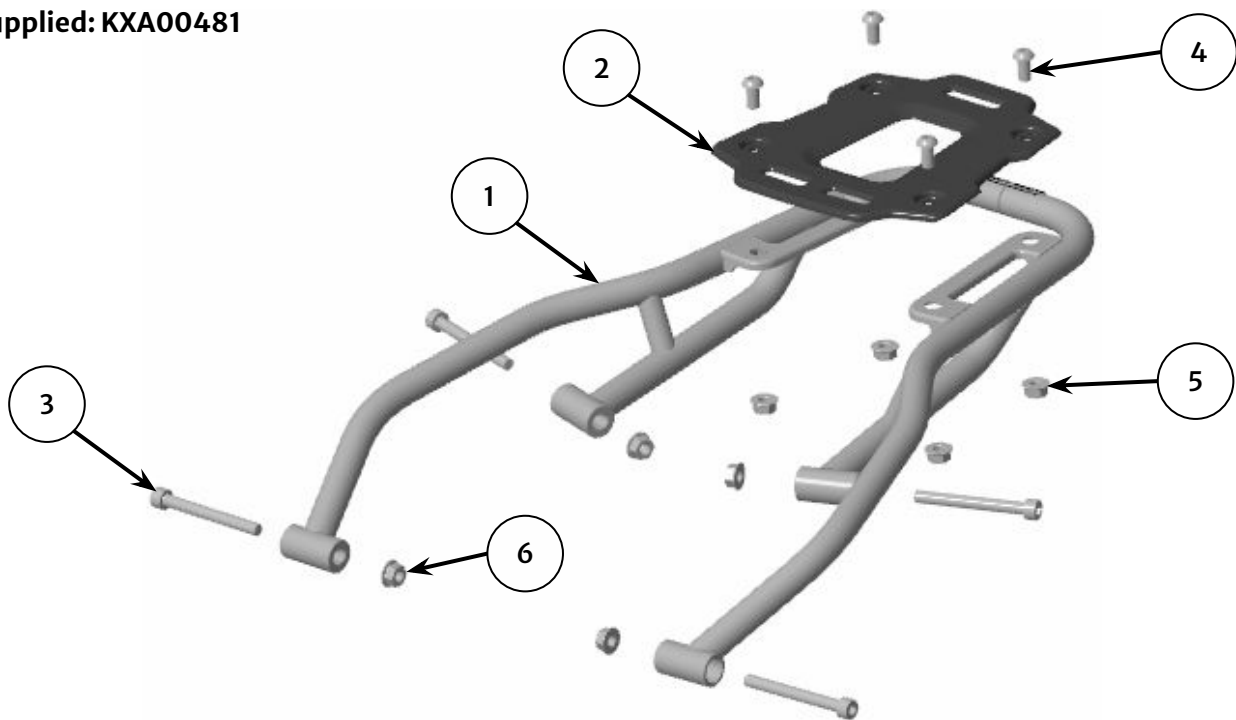

Item	Description	Qty
1	Rear rack	1
2	Top plate	1
3	Fixing, M8 x 75mm	4
4	Fixing, M8 x 16mm	4
5	Nut, M8	4
6	Nut, M8, black	4

1 Remove the seat as described in the Owner's Manual.

Remove the rear mudguard assembly (1) by first removing the two fixings located on the underside of the rear mudguard (2), and then the two fixings located beneath the seat area (3).

Retain the fixings for reuse and carefully place the rear mudguard assembly on the rear tyre.



5mm hexagonal bit and ratchet
10mm socket and ratchet

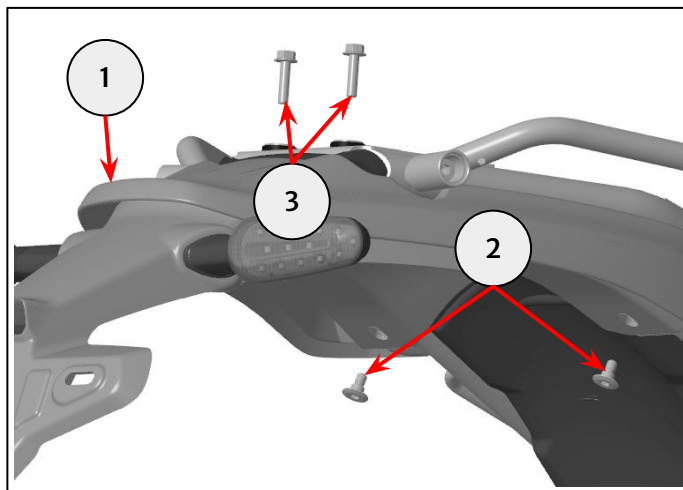

2 Remove the fixings securing the right hand grab handle (1).

Retain the fixings (2), washers (3) and nuts (4) for reuse. Retain the grab handle for reuse if the motorcycle is to be returned to its original condition.

Repeat for the left hand grab handle.



6mm hexagonal bit and ratchet
12mm spanner

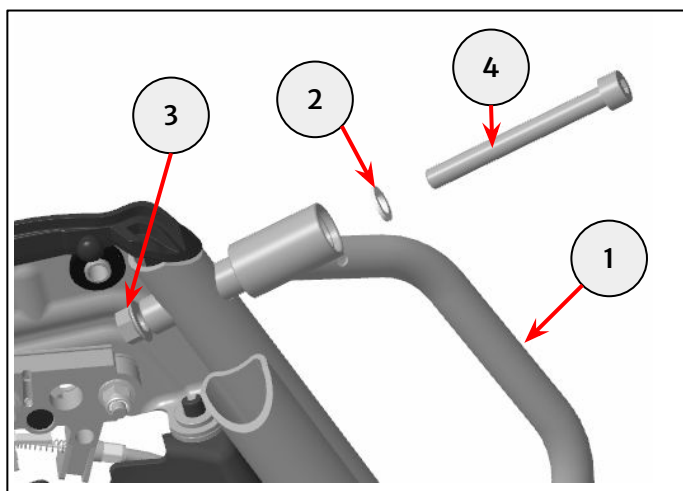
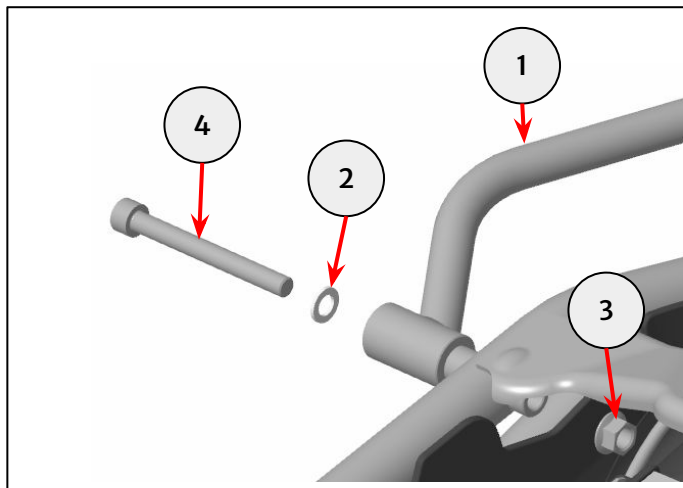

3 Collect the rear rack (1) and assemble to the mounts on the frame using the four M8 x 75mm fixings (2), four M8 nuts with a black finish (3) from the kit. Reuse the four washers (4) removed in step 2.

Tighten fixings to **45 Nm**.



5mm hexagonal bit and torque wrench
10mm spanner

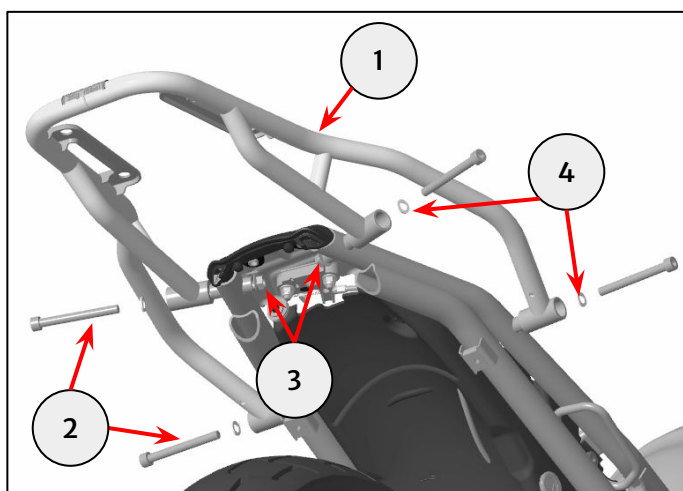

6 Refit the rear mudguard assembly (1) by first assembling the two fixings located below the pillion seat (2), followed by the two fixings located on the underside of the rear mudguard (3).

Tighten the fixings to 10Nm.



5mm hexagonal bit and torque wrench
10mm socket and torque wrench

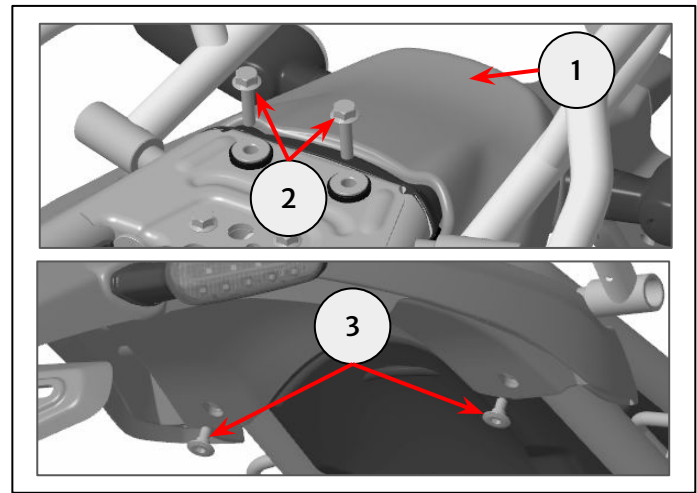

7 Fit the top plate (1) to the rack using four M8 x 16mm fixings (2) and four M8 nuts with a silver finish (3) from the kit.

Tighten the fixings to 15Nm.

Refit the seat as described in the Owner's Manual.



5mm hexagonal bit and torque wrench
12mm spanner

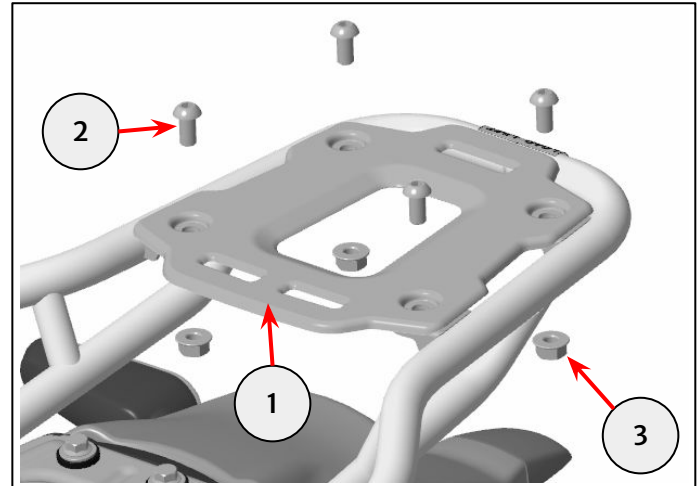

WARNING: After fitting any genuine Royal Enfield accessory always ride the motorcycle with caution and allow time to become familiar with any change in the motorcycle handling characteristics. Failure to become familiar with any change in the motorcycle handling characteristics may cause the motorcycle to become unstable and result in an accident.