

Part Number:
KXA00220

Models:
Super Meteor
VIN starting with ME3P7B6FHN10007

WARNING: Royal Enfield genuine accessories are designed to fit only the specific Royal Enfield motorcycle(s) that are specified above. They should not be fitted to any other type of motorcycle. Pay particular attention to the warnings and cautions contained in this instruction, failure to do so may result in an incorrect installation of the accessory which could result in an unsafe riding condition and possible accident. If in any doubt always seek help from your authorised Royal Enfield dealer.

WARNING: Before starting any accessory kit installation ensure the motorcycle is supported in a stable condition. Failure to support the motorcycle correctly could lead to motorcycle damage or personal injury.

WARNING: All fixings must be tightened to the torque values specified in this instruction. Failure to tighten fixings to the correct torque could result in an unsafe riding condition and possible accident

CAUTION: Care should be taken when fitting any accessory kit. Incorrect handling of kit components or the use of incorrect tools could lead to component or motorcycle damage.

NOTE: The content of this instruction is subject to change at any time without notice or liability. Royal Enfield reserves the right to revise the information presented at any time.

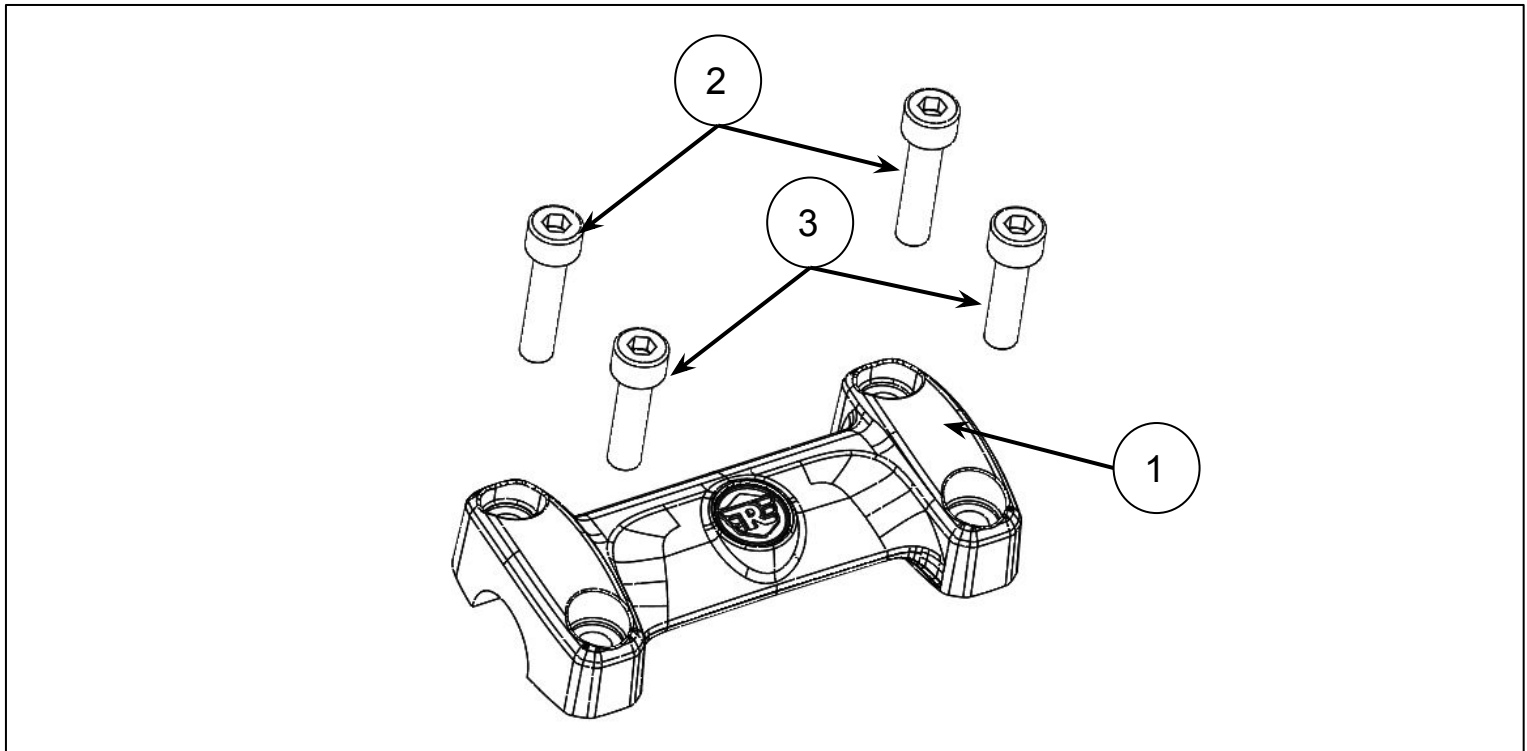

| Item | Description | Qty |
|------|-------------------|-----|
| 1 | Handlebar Clamp | 1 |
| 2 | Fixing, M8 X 35mm | 2 |
| 3 | Fixing, M8 X 30mm | 2 |

1 While supporting the handlebar (1), remove the fixings (2) and the handlebar clamps (3). Carefully rest the handlebar on the instrument cluster.

Retain the handlebar clamps and fixings for reuse if the motorcycle is to be returned to its original condition.

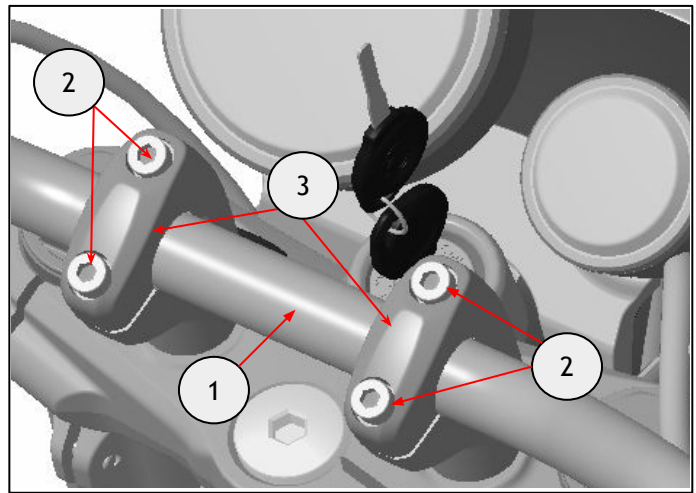
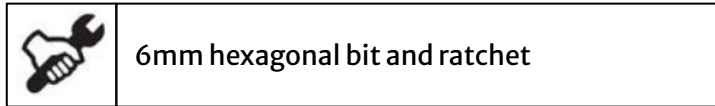

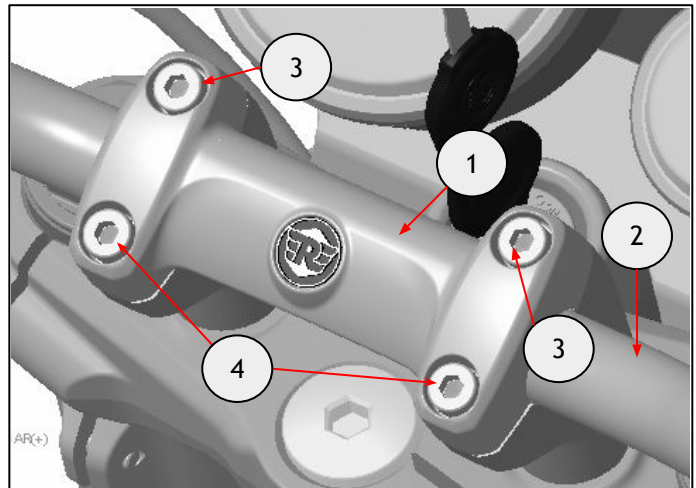
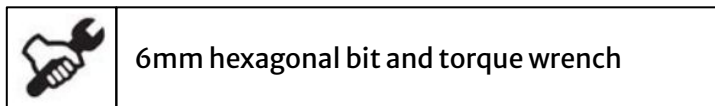

2 Fit the handlebar clamp (1) over the handlebar (2) using the M8 x 35 (3) and M8 x 30 (4) fixings from the kit.

Tighten the upper fixings (3) to **20 Nm**. Loosely tighten the fixings (4) to allow movement of the handlebar.

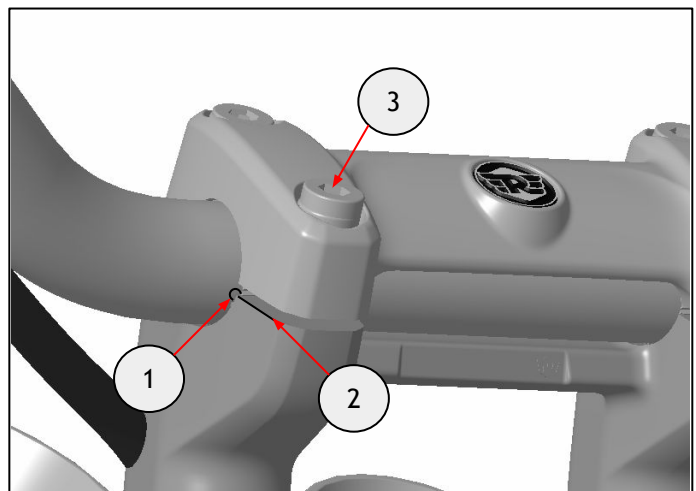
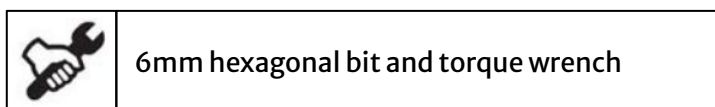

3 Align the positioning mark (1) on the handlebar with the top of the handlebar riser (2). Tighten the fixings (3) to **20 Nm**.



 **WARNING:** After fitting any genuine Royal Enfield accessory always ride the motorcycle with caution and allow time to become familiar with any change in the motorcycle handling characteristics. Failure to become familiar with any change in the motorcycle handling characteristics may cause the motorcycle to become unstable and result in an accident.