

Part Number:
1990556

Models:
Interceptor Bear 650 (all years)
Interceptor (648cc, all years)
Continental GT (648cc, all years)
Super Meteor 650 (all years)
Shotgun 650 (all years)

WARNING: Royal Enfield genuine accessories are designed to fit only the specific Royal Enfield motorcycle(s) that are specified above. They should not be fitted to any other type of motorcycle. Pay particular attention to the warnings and cautions contained in this instruction, failure to do so may result in an incorrect installation of the accessory which could result in an unsafe riding condition and possible accident. If in any doubt always seek help from your authorised Royal Enfield dealer.

WARNING: Before starting any accessory kit installation ensure the motorcycle is supported in a stable condition. Failure to support the motorcycle correctly could lead to motorcycle damage or personal injury.

WARNING: All fixings must be tightened to the torque values specified in this instruction. Failure to tighten fixings to the correct torque could result in an unsafe riding condition and possible accident

CAUTION: Care should be taken when fitting any accessory kit. Incorrect handling of kit components or the use of incorrect tools could lead to component or motorcycle damage.

NOTE: The content of this instruction is subject to change at any time without notice or liability. Royal Enfield reserves the right to revise the information presented at any time.

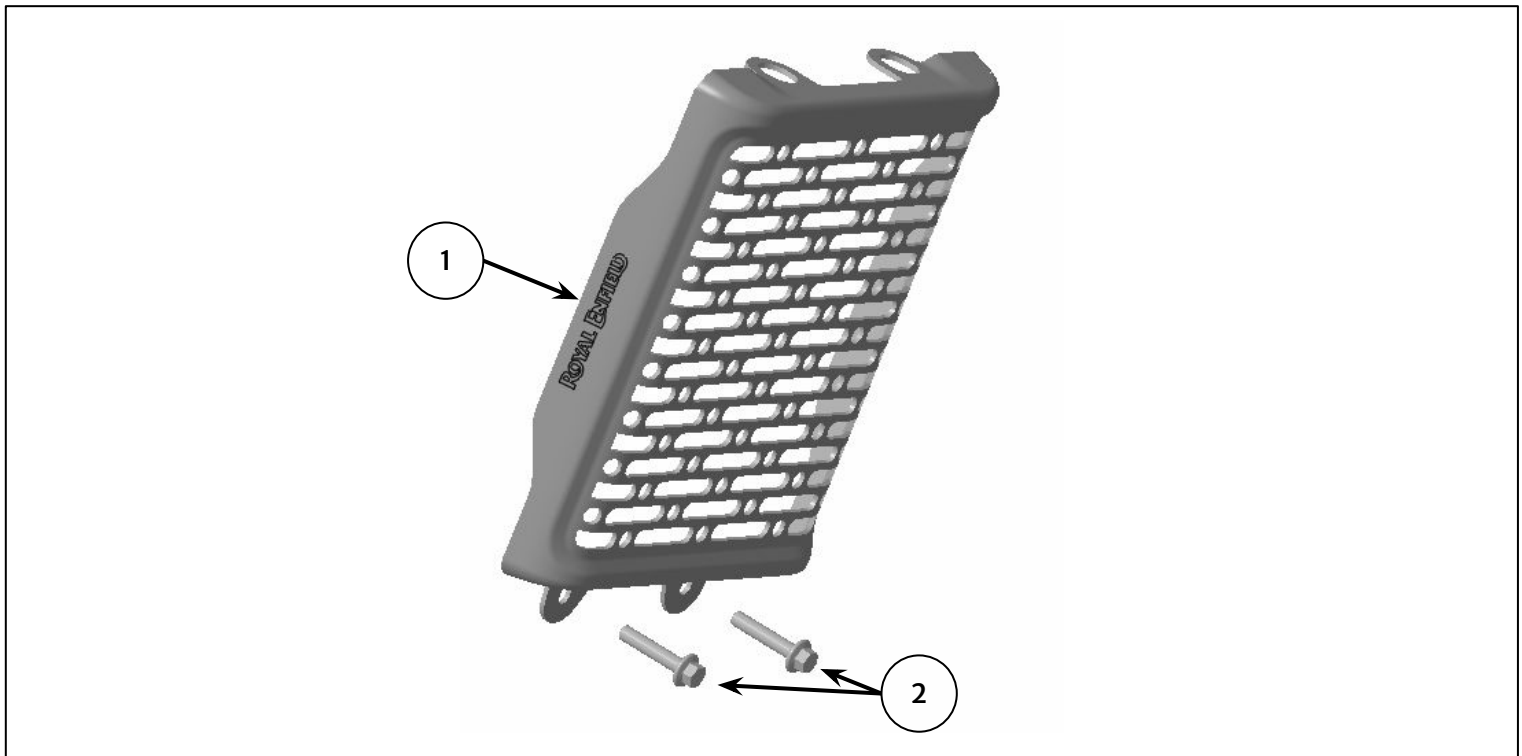

Item	Description	Qty
1	Oil cooler guard	1
2	Fixing, M6 x 30mm	2

For Interceptor Bear, Interceptor and Continental GT models only

1 Remove the two upper fixings and nuts (1). Retain for reuse if the motorcycle is to be returned to its original condition.



10mm socket, ratchet and 10mm spanner

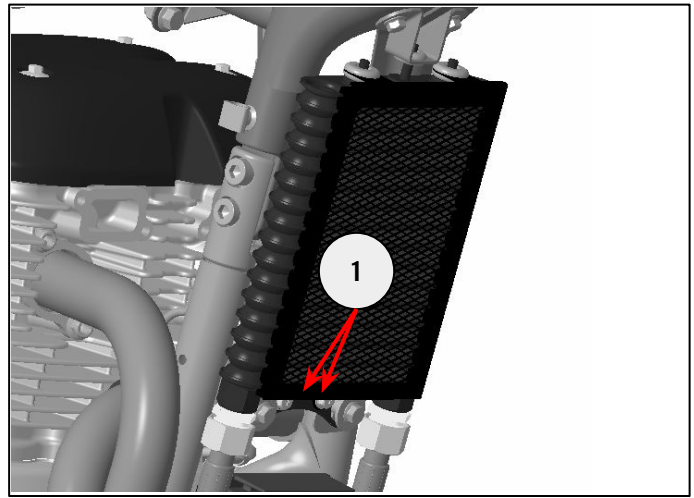

For Super Meteor and Shotgun models only

2 Remove the two lower fixings (1). Retain for reuse if the motorcycle is to be returned to its original condition.



10mm socket and ratchet

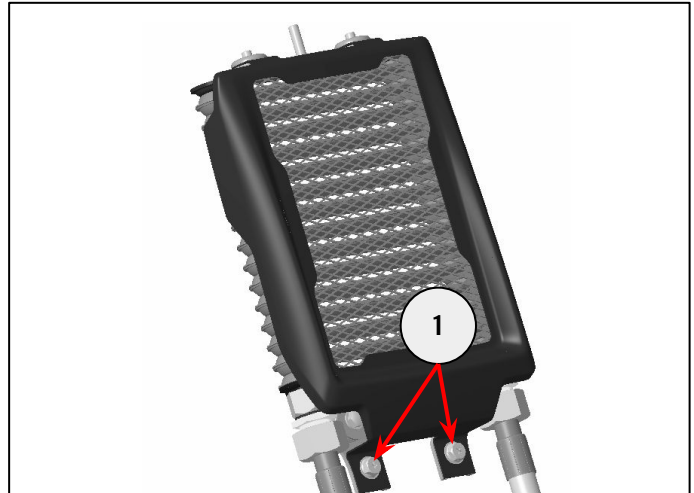

All models

3 Pull the standard oil cooler guard (1) towards the front of the bike from the bottom of the guard. Lift upwards to remove the guard from the top locating pins (2). Retain all for reuse if the motorcycle is to be returned to its original condition.

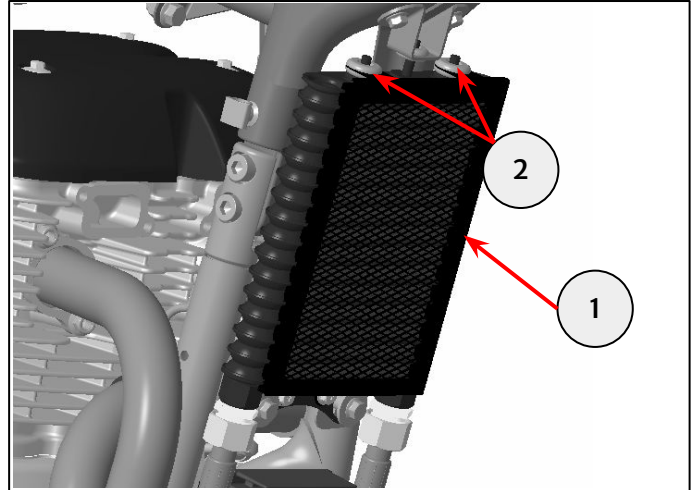

4 Remove the two fixings (1) and nuts (2). Note: some models are fitted with a fixed plate where the nuts will remain in place.

Support the oil cooler, do not allow to hang from its hoses. Ensure both grommets (3) and top hats (4) remain in place.

Retain the nuts (if applicable) for reuse. Retain the fixings (1) for reuse if the motorcycle is to be returned to its original condition.



10mm socket, ratchet and 10mm spanner

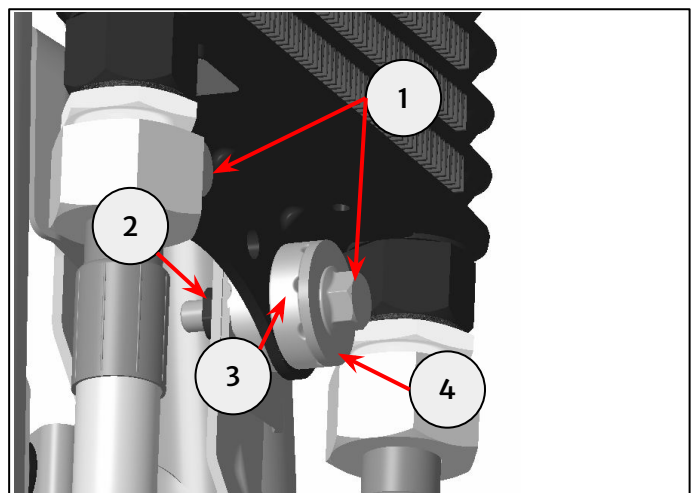

5 Remove the grommets (1) from the standard oil cooler guard (2).

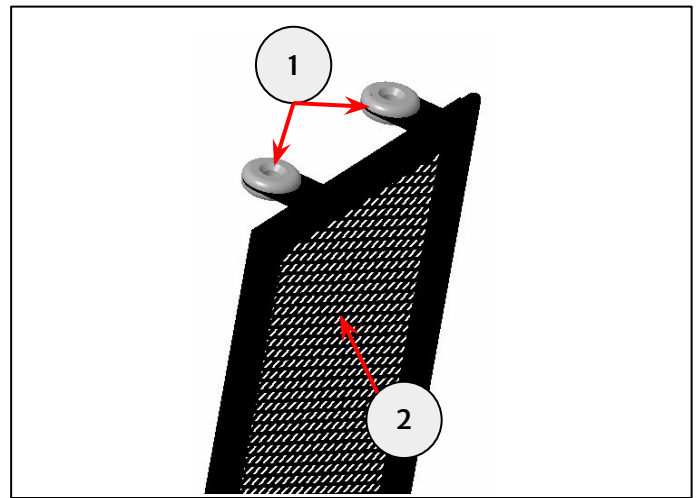

6 Refit the grommets (1) to the new oil cooler guard (2).

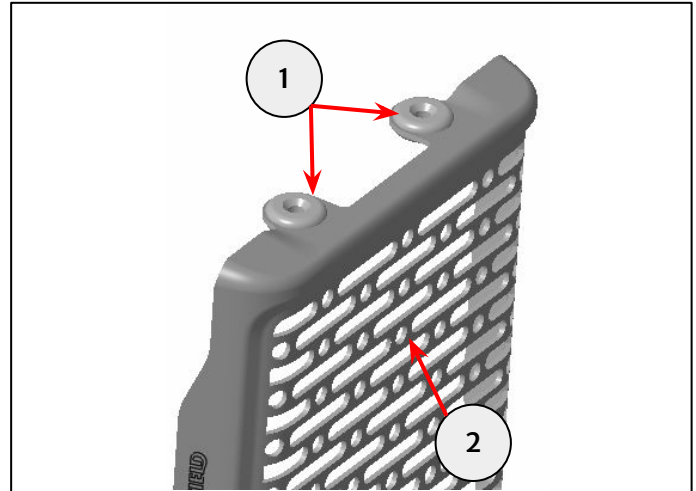

7 Locate the top of the new oil cooler guard (1) onto the oil cooler locating pins (2) and push downwards. Using the fixings from the kit and the nuts removed in step 4 (3), secure the oil cooler and new cooler guard to the bottom mounts. Tighten to **10Nm**.

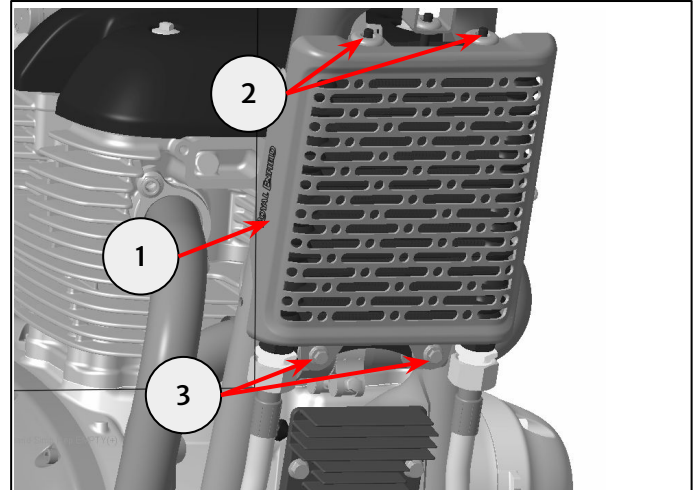

10mm socket, torque wrench and 10mm spanner



WARNING: After fitting any genuine Royal Enfield accessory always ride the motorcycle with caution and allow time to become familiar with any change in the motorcycle handling characteristics. Failure to become familiar with any change in the motorcycle handling characteristics may cause the motorcycle to become unstable and result in an accident.