

**Part Number:**

1990442

**Models :**

Continental GT 650 (2018 onwards)

Interceptor INT 650 (2018 onwards)

INT 650 (US Only) (2018 onwards)

**WARNING:** Royal Enfield genuine accessories are designed to fit only the specific Royal Enfield motorcycle(s) that are specified above. They should not be fitted to any other type of motorcycle. Pay particular attention to the warnings and cautions contained in this instruction, failure to do so may result in an incorrect installation of the accessory which could result in an unsafe riding condition and possible accident. If in any doubt always seek the help from your authorised Royal Enfield dealer.

**WARNING:** Before starting any accessory kit installation ensure the motorcycle is supported in a stable condition. Failure to support the motorcycle correctly could lead to motorcycle damage or personal injury.

**WARNING:** All fixings must be tightened to the torque values specified in this instruction. Failure to tighten fixings to the correct torque could result in an unsafe riding condition and possible accident.

**CAUTION:** Care should be taken when fitting any accessory kit. Incorrect handling kit components or the use of incorrect tools could lead to component or motorcycle damage.

**NOTE:** The content of this instruction is subject to change at any time without notice or liability. Royal Enfield reserves the right to revise the information presented at any time.

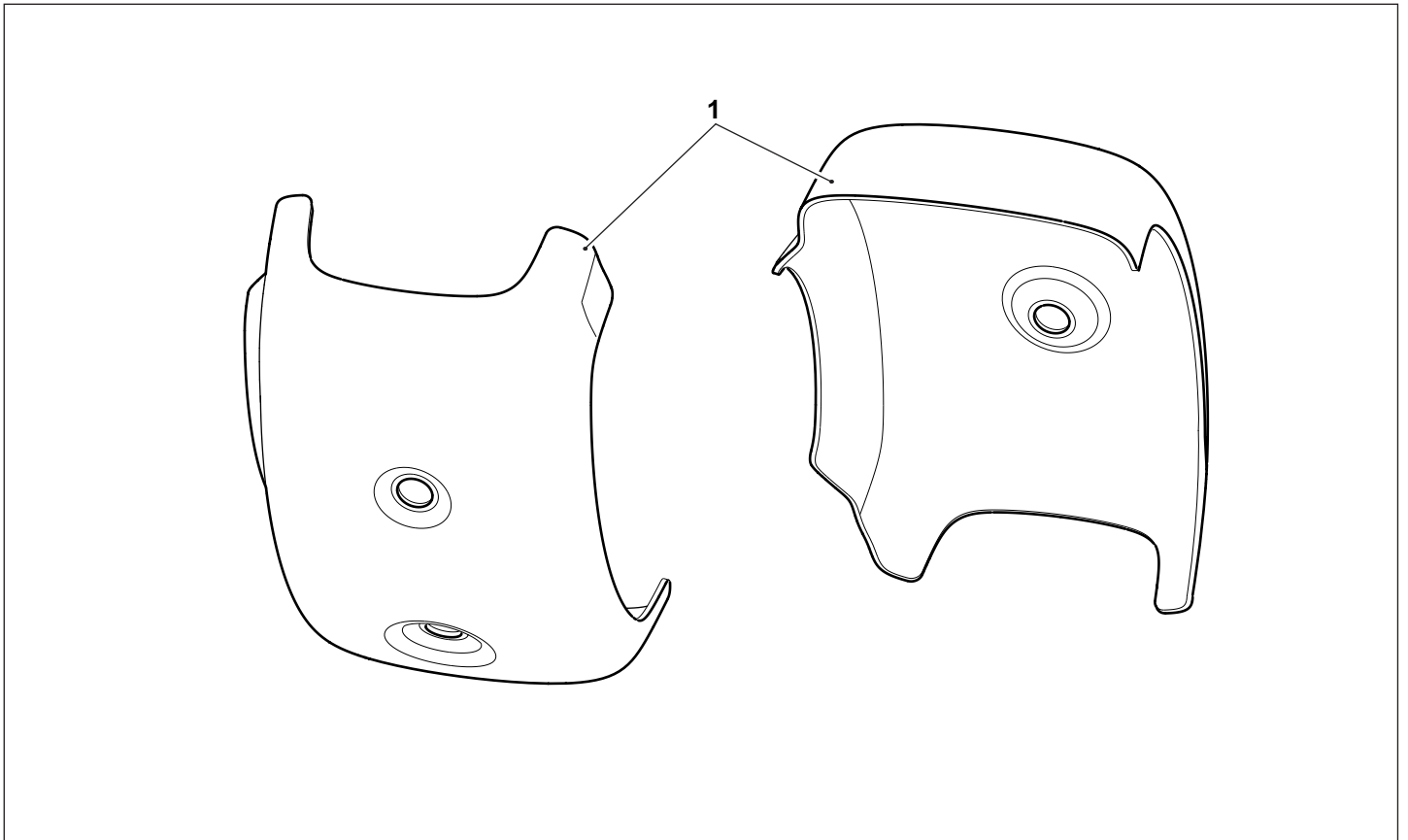

Item	Description	Qty
1	Intake cover	2

**WARNING:** If the engine has recently been running the engine and exhaust system will be hot. Before working near to the engine or exhaust system always allow time for the engine and exhaust system to cool. Touching any part of a hot engine or exhaust system will cause burn injuries.

**1** Remove the two fixings (1) securing the original intake cover (2) on the left hand side of the motorcycle. Retain the fixings for re-use. Retain the intake cover for reuse if the motorcycle is returned to its original condition.

	4mm Allen socket with ratchet
---	-------------------------------

**2** Position one of the accessory intake covers (2) from the kit on to the EFI assembly.

**NOTE:** The orientation of the intake cover (2) must be as shown, with the curved profile (3) of the cover positioned towards the rear of the motorcycle.

Align the intake cover with the original fixing positions. Refit the original fixings (1) and tighten the fixings to **10 Nm**.

	4mm Allen socket with torque wrench
---	-------------------------------------

**3** Repeat steps 1 and 2 for the right hand side of the motorcycle.

**NOTE:** The orientation of the intake cover (2) must be as shown, with the curved profile (3) of the cover positioned towards the rear of the motorcycle.

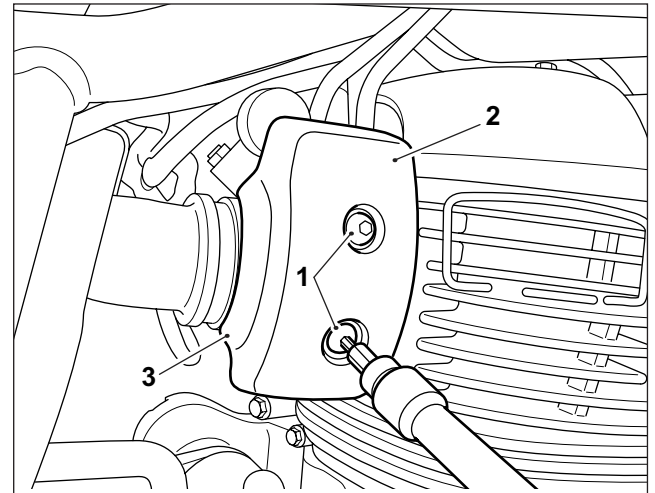
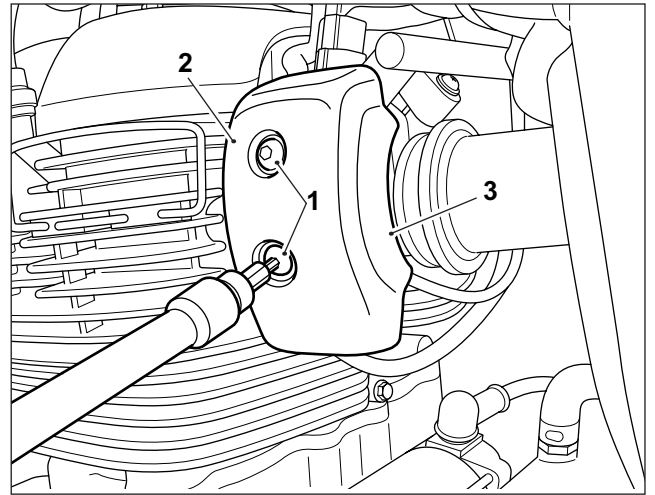

**WARNING:** After fitting any genuine Royal Enfield accessory always ride the motorcycle with caution and allow time to become familiar with any change in the motorcycle handling characteristics. Failure to become familiar with any change in the motorcycle handling characteristics may cause the motorcycle to become unstable and result in an accident.