



Part Number:
KXA00472

Models:
Guerrilla 450

 **WARNING:** Royal Enfield genuine accessories are designed to fit only the specific Royal Enfield motorcycle(s) that are specified above. They should not be fitted to any other type of motorcycle. Pay particular attention to the warnings and cautions contained in this instruction, failure to do so may result in an incorrect installation of the accessory which could result in an unsafe riding condition and possible accident. If in any doubt always seek help from your authorised Royal Enfield dealer.

 **WARNING:** Before starting any accessory kit installation ensure the motorcycle is supported in a stable condition. Failure to support the motorcycle correctly could lead to motorcycle damage or personal injury.

 **WARNING:** All fixings must be tightened to the torque values specified in this instruction. Failure to tighten fixings to the correct torque could result in an unsafe riding condition and possible accident

 **CAUTION:** Care should be taken when fitting any accessory kit. Incorrect handling of kit components or the use of incorrect tools could lead to component or motorcycle damage.

NOTE: The content of this instruction is subject to change at any time without notice or liability. Royal Enfield reserves the right to revise the information presented at any time.

Parts Supplied: KXA00472

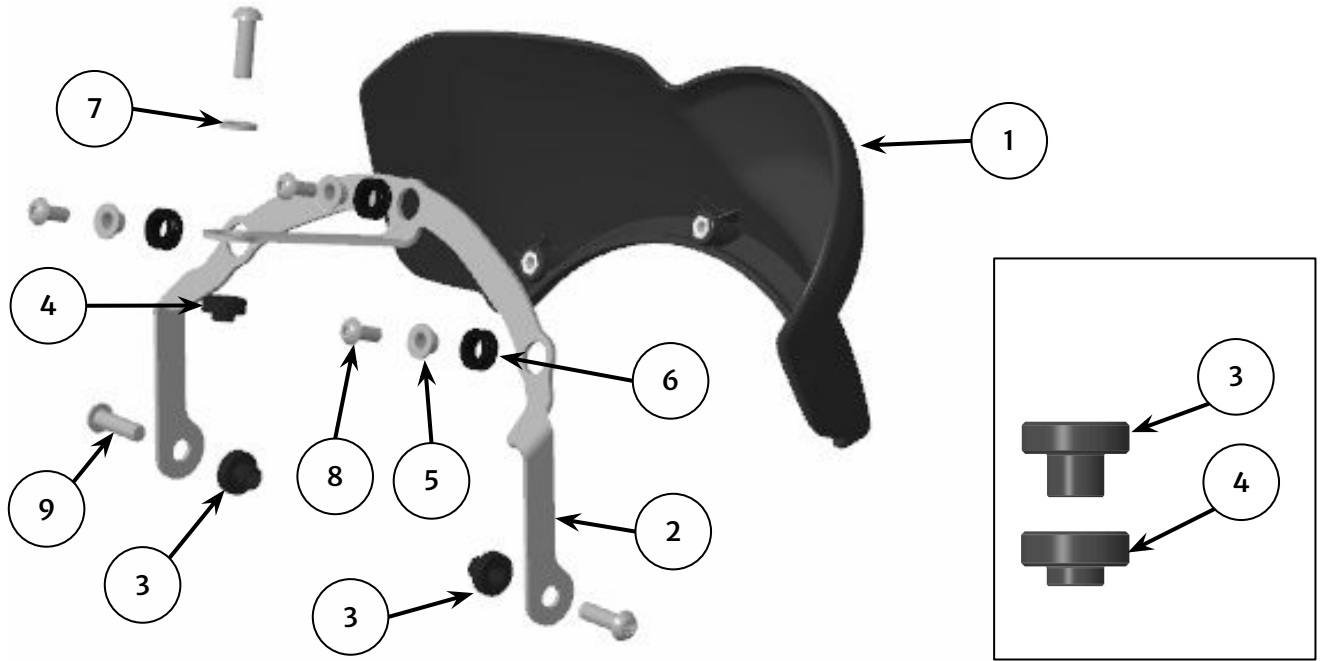

Item	Description	Qty
1	Instrument cowl	1
2	Mounting bracket	1
3	Spacer, 11mm	2
4	Spacer, 8mm	1
5	Top hat	3
6	Rubber grommet	3
7	Washer, M6	1
8	Fixing, M5 x 12mm	3
9	Fixing, M6 x 20mm	3

1 Fit the three rubber grommets (1) and three top hats (2) from the kit to the mounting bracket (3), as shown.

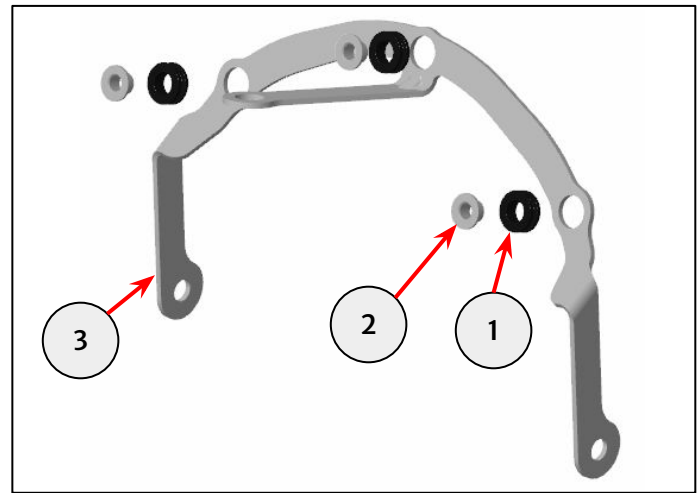

2 Assemble the instrument cowl (1) to the mounting bracket (2) with three M5 x 12mm fixings (3) from the kit.

Tighten fixings to 5Nm.

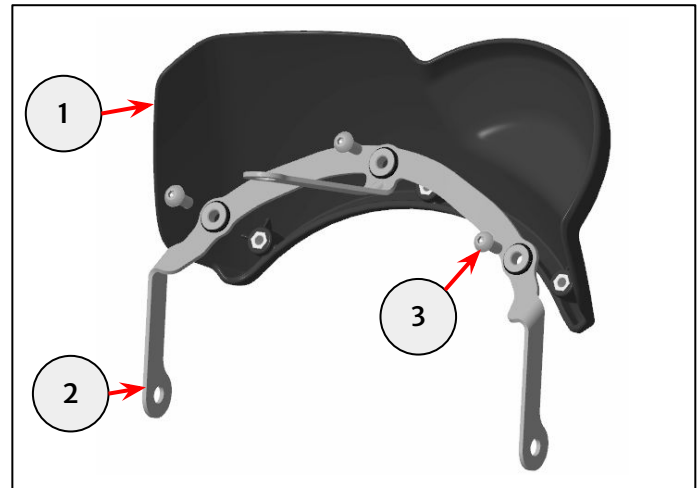
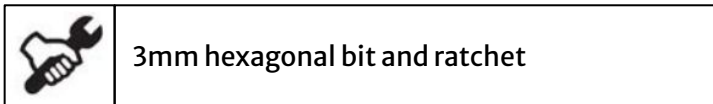

3 Remove the fixing (1) from the cockpit panel (2) and retain for reuse if the motorcycle is to be returned to its original condition.

Collect the 8mm spacer (2), from the kit and place in cockpit panel mount as shown.

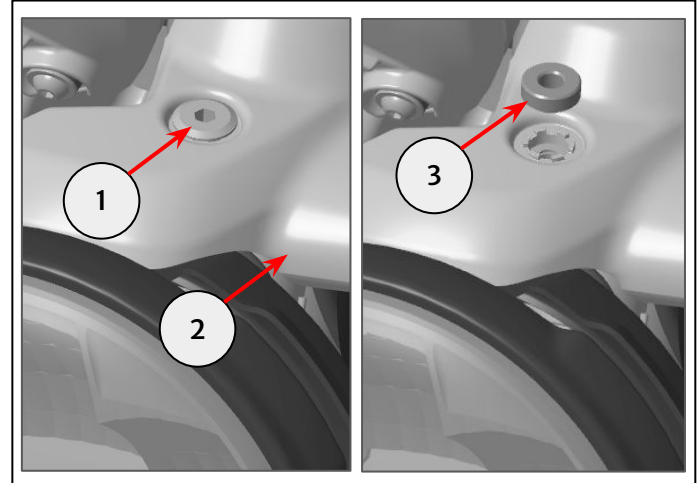
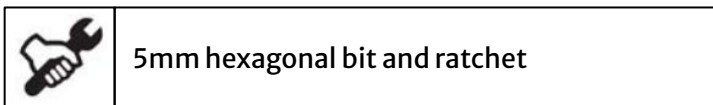

4 Remove the fixings (1) on each side of the headlight unit and retain for reuse if the motorcycle is to be returned to its original condition.

Collect the two 11mm spacers (2), from the kit and place within the grommets (3) on each side of the headlight unit.

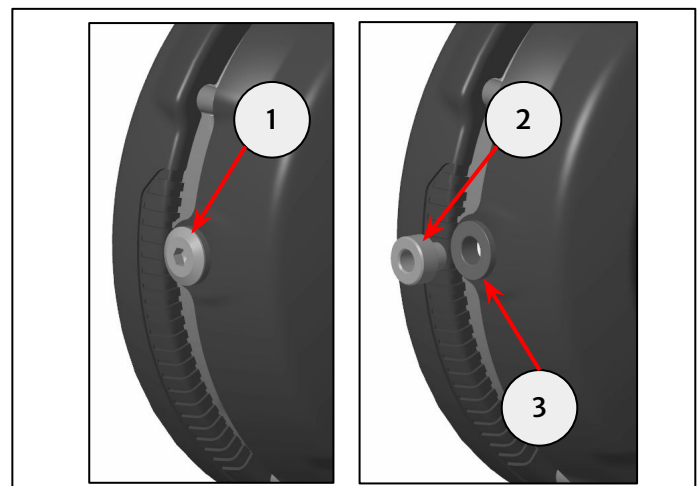
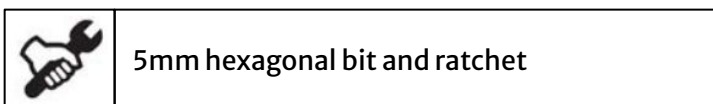

5 Align the instrument cowl assembly (1) with the side mounts on the headlight unit with two M6 x 20mm fixings (2).

Tighten fixings to **4Nm**.



T30 Torx bit and torque wrench

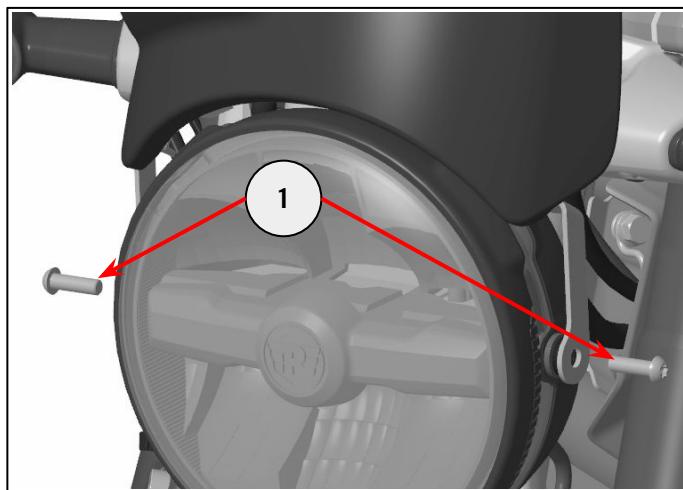

6 Secure the center mount with an M6 x 20mm fixing (1) and M6 washer (2) supplied in the kit and tighten to **9Nm**.

Tighten the fixings through the side mount as detailed in step 5 to **4Nm**.



T30 Torx bit and torque wrench

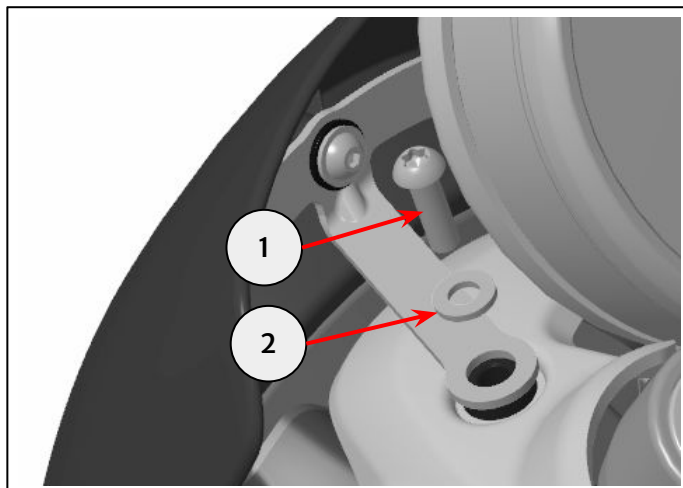

WARNING: After fitting any genuine Royal Enfield accessory always ride the motorcycle with caution and allow time to become familiar with any change in the motorcycle handling characteristics. Failure to become familiar with any change in the motorcycle handling characteristics may cause the motorcycle to become unstable and result in an accident.